

**Instruction Manual**

**No. EB 2002AS**

for

**M.F./H.F. A.M./F.M.**

**Signal Generator**

**TF 2002AS**



**Instruction Manual**  
**No. EB 2002AS**  
**for**  
**M.F./H.F. A.M./F.M.**  
**Signal Generator**  
**TF 2002AS**

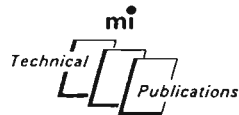



# Contents

## Chapter 1 GENERAL INFORMATION

1.1	Features ... ..	3
1.2	Data summary ... ..	4
1.3	Accessories .. ...	8

## Chapter 2 OPERATION

2.1	Preparation for use ... ..	11
2.2	Fuses ... ..	11
2.3	Controls - supply and tuning ...	12
2.4	Controls - modulation and output	13
2.5	Setting frequency ... ..	14
2.6	Amplitude modulation.. ...	17
2.7	Frequency modulation.. ...	18
2.8	Setting output ... ..	19
2.9	Mismatched loads ... ..	20
2.10	Use of dummy aerial and d.c. isolator	22
	<b>Decibel conversion tables ... ..</b>	<b>23</b>

## Chapter 3 TECHNICAL DESCRIPTION

3.1	Circuit summary ... ..	25
3.2	Carrier oscillators ... ..	26
3.3	Wide band amplifier ... ..	27
3.4	Output filters . ... ..	28
3.5	A. L. C. and envelope feedback..	28
3.6	Modulation oscillator .. ...	28
3.7	Amplitude modulation drive circuits	29
3.8	A. M./F. M. drive and monitor..	29
3.9	Frequency modulation drive circuits	29
3.10	Crystal calibrator ... ..	30
3.11	Attenuators... ..	31
3.12	R. F. unit filters ... ..	31
3.13	Power supplies ... ..	31

## Chapter 4 MAINTENANCE

4.1	Introduction... ..	33
4.2	Screw fasteners ... ..	33
4.3	Removal of case ... ..	33
4.4	Location of sub-assemblies and components. ... ..	33
4.5	Circuit voltages ... ..	35
4.6	Waveforms ... ..	38
4.7	Cleaning rotary switches ... ..	39

## Chapter 5 REPAIR AND ALIGNMENT

5.1	General ... ..	41
5.2	Fault location ... ..	41
5.3	Preset controls ... ..	41

## Chapter 6 REPLACEABLE PARTS

Introduction and ordering ... ..	50
Main chassis ... ..	50
Units:	
1 and 2 ... ..	53
3 ... ..	54
4 ... ..	55
5 and 6 ... ..	56
7 and 8 ... ..	58
9 to 11 ... ..	59
12 to 14 ... ..	60
15 and 16 ... ..	61
17 to 22 ... ..	62
23 to 25 ... ..	63
26 ... ..	64
27 to 30 ... ..	65
31 ... ..	66

## Chapter 7 CIRCUIT DIAGRAMS

Circuit notes ... ..	68	Fig. 7.6 Modulation oscillator ... ..	79
Fig. 7.1 Interconnection diagram ...	69	Fig. 7.7 A. M./F. M. drive and monitor	81
Fig. 7.2 Oscillators ... ..	71	Fig. 7.8 Crystal calibrator .. ...	83
Fig. 7.3 Wide band amplifier ... ..	73	Fig. 7.9 Attenuators ... ..	85
Fig. 7.4 Carrier filters ... ..	75	Fig. 7.10 R. F. unit filters ... ..	87
Fig. 7.5 A. L. C. and envelope feedback	77	Fig. 7.11 Power supplies ... ..	87

## 1.1 FEATURES

This all transistorized signal generator gives high quality a. m. outputs from 10 kHz to 72 MHz; f. m. outputs are provided between 100 kHz and 72 MHz. It has very high frequency discrimination which, coupled with the good stability reached soon after switching on, makes it particularly suitable for setting up and adjusting crystal controlled receivers where the channel spacing is small and the i. f. pass band must have an accurate absolute setting. Another feature of note is the low leakage which will be found of advantage for tests on receivers that have an internal ferrite rod aerial.

The instrument is rugged yet compact in design and is fitted with a removable lid to protect the front panel, and to provide stowage for the accessories.

Permeability tuning of the oscillator and output modules provides the low impedance required by the transistor circuitry and enables the complete range to be covered in only eight bands. The hand calibrated near-logarithmic tuning scale is displayed in a continuous zig-zag pattern, with scales running alternately left and right, which cuts out much of the tedium usually associated with tuning about the band-change frequencies. Above 100 kHz carrier frequency, direct reading incremental tuning gives high discrimination. Carrier shifts can also be produced by externally applied d. c.

Crystal check points are available at intervals of 1 MHz, 100 kHz or 10 kHz. Subsidiary check points can be switched in at 1 kHz relative to each of the main points. The dial of the incremental control can be standardized against the crystal check points by means of two independent trimmer controls.

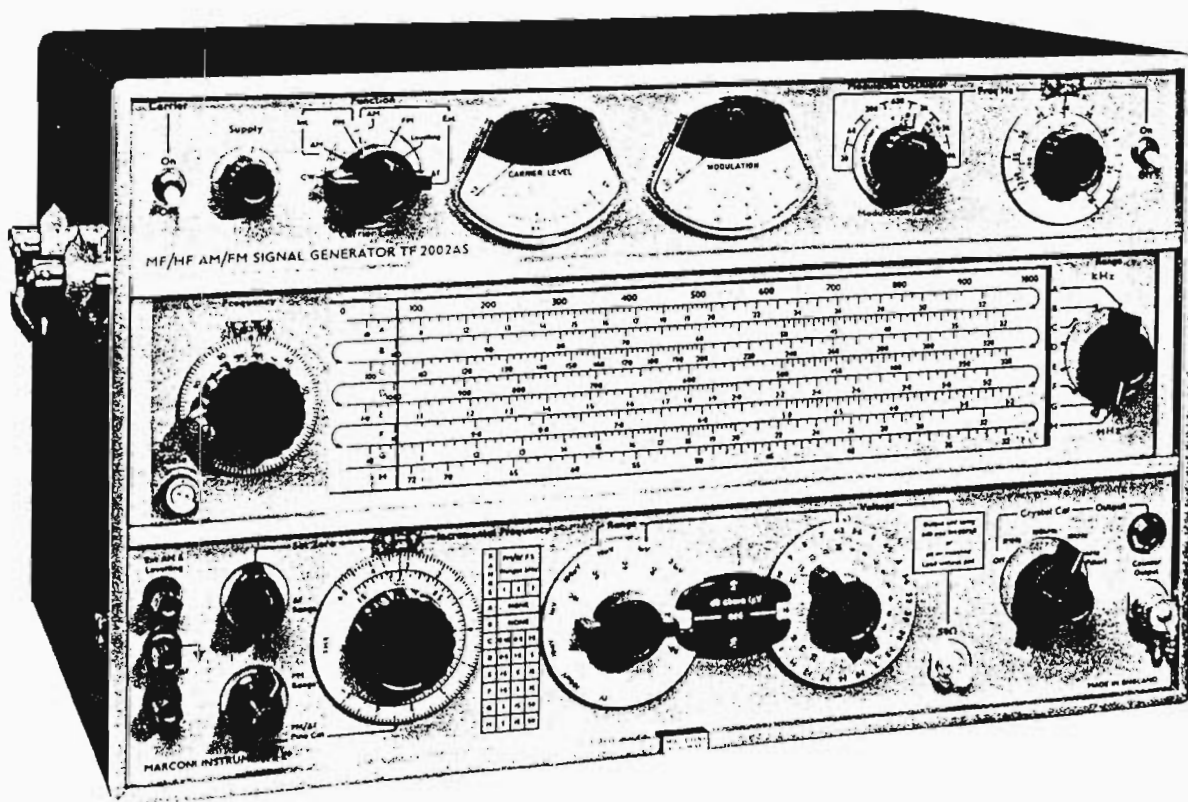

Fig. 1.1 TF 2002AS M.F./H.F. A.M./F.M. Signal Generator

The whole system can provide a degree of scale expansion equivalent to a total scale length of over 3/4 of a mile.

Up to 2 V source e. m. f. can be obtained with 100% modulation over most of the range. Output is controlled by cam operated 20 dB and 1 dB step attenuators with voltage and dB calibration in terms of p. d. across a 50  $\Omega$  load or of source e. m. f. ; interpolation between attenuator steps is provided by the carrier level control and meter. Automatic level control holds the output constant against frequency or range changing.

An auxiliary unmodulated output is available for such purposes as driving a counter to monitor the signal generator frequency.

Internal a. m. up to 100% is produced by a continuously tuned oscillator covering the audio band. This means that the generator can be used for comprehensive r. f. , i. f and a. f. response measurements on a receiver with no additional equipment other than a receiver output meter. The oscillator output is available for external use at terminals situated at the rear of the instrument.

Envelope negative feedback ensures a good modulation quality up to at least 80%, and modulation depth is independent of both carrier tuning and carrier level.

The continuously variable oscillator provides frequency modulation, and deviation is monitored directly on the modulation meter. Three ranges of deviation are provided for each carrier range above 100 kHz.

External frequency control terminals can be used to provide external frequency shift, phase modulation or, with the aid of a phase discriminator, phase locking of the carrier for maximum stability.

External amplitude control terminals can be used for level control or programming and very low frequency modulation without phase shift.

Emphasis has been placed on accessibility despite the compact structure and thorough screening. The instrument has three major horizontal sections; the centre one containing the oscillators and output circuits can be withdrawn and operated via an extension lead.

## 1.2 DATA SUMMARY

### Frequency

Range: 10 kHz to 72 MHz, in 8 bands:

A	10	-	32 kHz	E	1	-	3.2 MHz
B	32	-	100 kHz	F	3.2	-	10 MHz
C	100	-	320 kHz	G	10	-	32 MHz
D	320	-	1000 kHz	H	32	-	72 MHz

### Mechanical tuning discrimination:

The frequency scales are near logarithmic and a 1000 division linear logging scale is provided.

### Calibration accuracy:

$\pm 1\%$ , with the scale in the index position. Provision is made for adjusting the scale position against the internal crystal calibrator.

### Stability:

At constant ambient temperature within the range 10  $^{\circ}$ C to 35  $^{\circ}$ C.

In the 15 minute period commencing 3 hours after switch-on, the frequency variation is typically 30 p. p. m.  $\pm 3$  Hz, and will not exceed 90 p. p. m.  $\pm 3$  Hz. During the period 10 minutes to 3 hours after switch-on, the maximum frequency variation per 15 minutes will not exceed three times the amounts stated above.

Following a 10  $^{\circ}$ C change in the ambient temperature within the range 10  $^{\circ}$ C to 35  $^{\circ}$ C occurring after the above period of operation, the maximum frequency variation over the next 3 hours is typically 200 p. p. m. per 15 minutes.

Following a 10% change in the supply voltage, the maximum frequency variation is less than 20 p. p. m.  $\pm 5$  Hz.

Electrical fine tuning: Operative above 100 kHz only in 3 ranges as shown below:

Frequency	Band	$\Delta f$ range in kHz			Fine calibration	
		1	2	3	at	on range
100 - 320 kHz	C	$\pm 0.15$	$\pm 0.5$	$\pm 1.5$	$\pm 1.0$ kHz	3
320 - 1000 kHz	D	$\pm 0.5$	$\pm 1.5$	$\pm 5.0$	$\pm 1.0$ kHz	2
1 - 3.2 MHz	E	$\pm 1.5$	$\pm 5.0$	$\pm 15$	$\pm 10$ kHz	3
3.2 - 10 MHz	F	$\pm 1.5$	$\pm 5.0$	$\pm 15$	$\pm 10$ kHz	3
10 - 32 MHz	G	$\pm 5.0$	$\pm 15$	$\pm 50$	$\pm 50$ kHz	3
32 - 72 MHz	H	$\pm 5.0$	$\pm 15$	$\pm 50$	$\pm 50$ kHz	3

Incremental frequency is  $\pm 15\%$  of full scale when not standardized. The accuracy can be improved to  $\pm 5\%$  of full scale on the  $+\Delta f - \Delta f$  ranges, by use of the FINE CAL control and the internal crystal calibrator at the points in the tables above.

Discrimination

Better than 0.005% of carrier frequency.

Electrical fine tuning up to the maxima in the table above may be used as an external frequency shift facility for manual or automatic frequency control, frequency modulation, phase modulation or sweeping. See under Frequency Modulation. Sweep widths in excess of the table may be obtained: between 100 kHz and 320 kHz (Band C) up to  $\pm 2.5$  kHz is obtainable, and between 320 kHz and 1 MHz (Band D) up to  $\pm 15$  kHz.

The h. f. end of each band generally provides approximately x3 greater external sweep.

Crystal calibrator:

Check points at 1 MHz, 100 kHz and 10 kHz intervals.  
Accuracy: 0.01%, 10 - 35 °C.  
Check points at  $\pm 1$  kHz,  $\pm 10$  Hz about these points.

R.F. output

Level:

Maxima  
10 kHz - 32 MHz (c. w. or up to 100% a. m.)  
1 V e. m. f. using 6 dB pad, or 1 V p. d. across a matched load.  
32 MHz - 72 MHz  
As above for c. w. Half the above with 100% a. m.  
10 kHz - 72 MHz  
If working into an open circuit without a 6 dB pad, nominally 2 V e. m. f. is available using up to 30% modulation depth below 32 MHz, or using c. w. above 32 MHz.  
Variable down to 0.1  $\mu$ V at all frequencies.

(see also external levelling, under amplitude modulation.)

Attenuators:

Coarse - 120 dB in 20 dB steps.  
Fine - 20 dB in 1 dB steps.  
External 6 dB pad TM 5573/1.  
Increments less than 1 dB obtainable by meter setting.

**Total level accuracy:** (Above 1.0  $\mu$ V with or without 6 dB pad, with meter at the appropriate reference mark.)  
 Below 32 MHz  $\pm 1$  dB from 10  $^{\circ}$ C to 35  $^{\circ}$ C.  
 Above 32 MHz  $\pm 2$  dB, of which approximately  $\pm 1$  dB is caused by temperature effects over the range 10  $^{\circ}$ C to 35  $^{\circ}$ C.

A. L. C. maintains carrier level meter setting constant within 0.5 dB at all carrier frequencies.

**Impedance:** Effectively 50  $\Omega$  at all level settings.  
 V. S. W. R. 1.15 : 1 below 200 mV, with or without 6 dB pad.

**Carrier harmonics:** Less than 3% individual harmonics at maximum output levels.

**Leakage:** Negligible. Allows measurements to be made close to the signal generator.

**Counter output:** Suitable for use with Counter TF 1417/2 and Converter TF 2400.  
 Produces 10 mV into 50  $\Omega$  from high impedance source.

**Amplitude modulation**

**Depth:** Continuously variable up to nominally 100%.

**Monitor:** Reads equivalent peak modulation and is virtually independent of carrier level reference.

**Accuracy:** At 20  $^{\circ}$ C up to 80% depth,  $\pm 5\%$  modulation to 10 kHz, and  $\pm 10\%$  modulation to 20 kHz, provided the maximum usable modulation frequencies shown in Table 1.1 are not exceeded. The error with temperature may rise by an additional  $\pm 3\%$  modulation at 10  $^{\circ}$ C and 35  $^{\circ}$ C.

**Envelope distortion:** Using internal oscillator, less than 2% distortion factor at modulating frequency of 400 Hz for modulation depth up to 80% at carrier frequencies between 100 kHz and 32 MHz (Bands C to G). The maximum usable modulation frequencies for up to 5% distortion at 80% depth over the whole carrier range are shown in Table 1.1.

**Table 1.1**

Band	Carrier frequency	Maximum frequency for 80% modulation depth (5% distortion)
A	10 to 32 kHz	100 Hz
B	32 to 100 kHz	100 Hz
C	100 to 320 kHz	1.5 kHz
D	320 to 1000 kHz	2 kHz
E	1 to 3.2 MHz	20 kHz
F	3.2 to 10 MHz	20 kHz
G	10 to 32 MHz	20 kHz
H	32 to 72 MHz	20 kHz

**Internal oscillator:** Continuously variable. 20 Hz to 20 kHz in 6 ranges.  
 Accuracy 10%.  
 Output: fixed level sync. signal is available at rear terminals of approximately 1 V r.m. s. (from 10 k $\Omega$ ) with < 1.5% distortion.



External a. m. :	A. C. coupled. 20 Hz to 20 kHz. Accuracy of modulation depth and frequency limitations as for internal modulation. Input: approximately 1 V into 2.5 k $\Omega$ for nominal 100% a. m. (Depth adjustable at panel.)
External levelling:	D. C. coupled. Carrier level may be varied by external d. c. A -6.75 V potential (nominal) appears on the terminal when switched to this function. Input: approximately $\pm 6$ V d. c. (into 15 k $\Omega$ ) or 12 V p-p about the -6.75 V mean gives full control of the carrier.
Spurious f. m. on a. m.	For 30% a. m. up to 1 kHz modulation frequency.  Bands A - G: deviation less than 100 Hz +10 p. p. m. of carrier frequency.  Band H: deviation less than 50 p. p. m. of carrier frequency.
Spurious f. m. on c. w. :	Less than $\pm 1$ p. p. m. $\pm 5$ Hz of carrier frequency using mains operation.
Spurious a. m. on c. w. :	-65 dB relative to 30% modulation, in a 3 dB bandwidth of 650 Hz at carrier frequencies below 100 kHz, and in 20 kHz bandwidth above 100 kHz.
<b>Frequency modulation</b>	
Deviation:	Continuously variable with three ranges to maximum peak deviations as shown in the table under electrical fine tuning.
Modulation meter:	Indicates peak deviation.
Accuracy:	$\pm 15\%$ of full scale without standardization. $\pm 6\%$ of full scale when the $\Delta f$ system has been standardized, at the points shown under electrical fine tuning, with modulation frequencies between 20 Hz and 4 kHz. The error with temperature may rise by an additional $\pm 3\%$ of f. s. d. at 10 $^{\circ}\text{C}$ and 35 $^{\circ}\text{C}$ .
Distortion:	Less than 3% at maximum deviation with modulation frequencies from 20 Hz to 4 kHz.
Modulation frequency range:	With carriers above 1 MHz the modulation frequency range is extended to 20 kHz with a flatness of $\pm 2.0$ dB.
Internal oscillator:	As for amplitude modulation.
External f. m.	A. C. coupled. 20 Hz to 20 kHz, accuracy of deviation and frequency limitations as for internal modulation. Input: up to 1.5 V r. m. s. into 2.5 k $\Omega$ for maximum deviation as shown in table under electrical fine tuning (deviation adjustable at panel).
External $\Delta f$ :	D. C. coupled. Carrier frequency may be varied by d. c. A potential of -6.75 V (nominal) appears on the terminal when switched to this function. Input: up to $\pm 1$ V d. c. (into 100 k $\Omega$ ) or 2 V p-p about the -6.75 V mean is needed for maximum deviations given in table under electrical fine tuning.

## Power supply

### Mains operation

(absolute limits):

95 V to 130 V a. c.	}	45 to 500 Hz
190 V to 264 V a. c.		

load 15 VA approximately.

### Battery operation

(absolute limits): 19 V to 32 V d. c. positive earth, current 0.4 A maximum.

### Dimensions and weight

Height	Width	Depth	Weight
11 in	18 in	14 in	59 lb
(28 cm)	(46 cm)	(36 cm)	(32 kg)

## 1.3 ACCESSORIES

### Accessories supplied

- ① Trimming tool. M.I. code 22951-221
- ② Hexagon wrench for removing r.f. box cover M.I. code 22951-012. (stowed inside the instrument)
- ③ 6 dB Pad type TM 5573/1; BNC plug to BNC socket. (stowed in clip at the rear of the instrument)
- ④ Output Lead, type TM 4969/3; BNC plug to BNC plug.
- ⑤ Telephone Jack Plug. M.I. code 23421-607. For crystal calibrator output socket.
- ⑥ Mains lead. M.I. code 43122-017.
- ⑦\* 2:1 Voltage Ratio Matching Pad type TM 5573/3; 50 to 75  $\Omega$  BNC plug to BNC socket.

\* TM 5573/3 is a 3 resistor pad which introduces a 2:1 voltage ratio but provides a 2 way match.

### Accessories available

- ⑧ Output Lead, type TM 4726/152; BNC plug to Belling-Lee L788FP plug.
- ⑨\*\* Matching Pad, type TM 5569; 50 to 75  $\Omega$ , BNC socket to Belling Lee L734/P plug.
- ⑩ Matching Pad, type TM 6599; 50 to 75  $\Omega$ . BNC plug to Burndep PR4E plug.
- ⑪ Dummy Aerial D. C. Isolating Unit, type TM 6123; input, BNC plug on 3 ft lead; output, spring loaded terminals. For general receiver testing or for use on circuits with d. c. potentials up to 350 V.
- ⑫ Matching transformer, type TM 5955/5; 50  $\Omega$  unbalanced to 300  $\Omega$  balanced, BNC socket to 4 mm terminals. Voltage ratio 1:0.5 +0.5.

\*\* TM 5569 is a 25  $\Omega$  series resistor and provides unity voltage ratio.

Rack mounting-kit, type TM 8269; consists of brackets and covers to convert bench mounting model TF 2002AS for mounting in a 19 in rack.

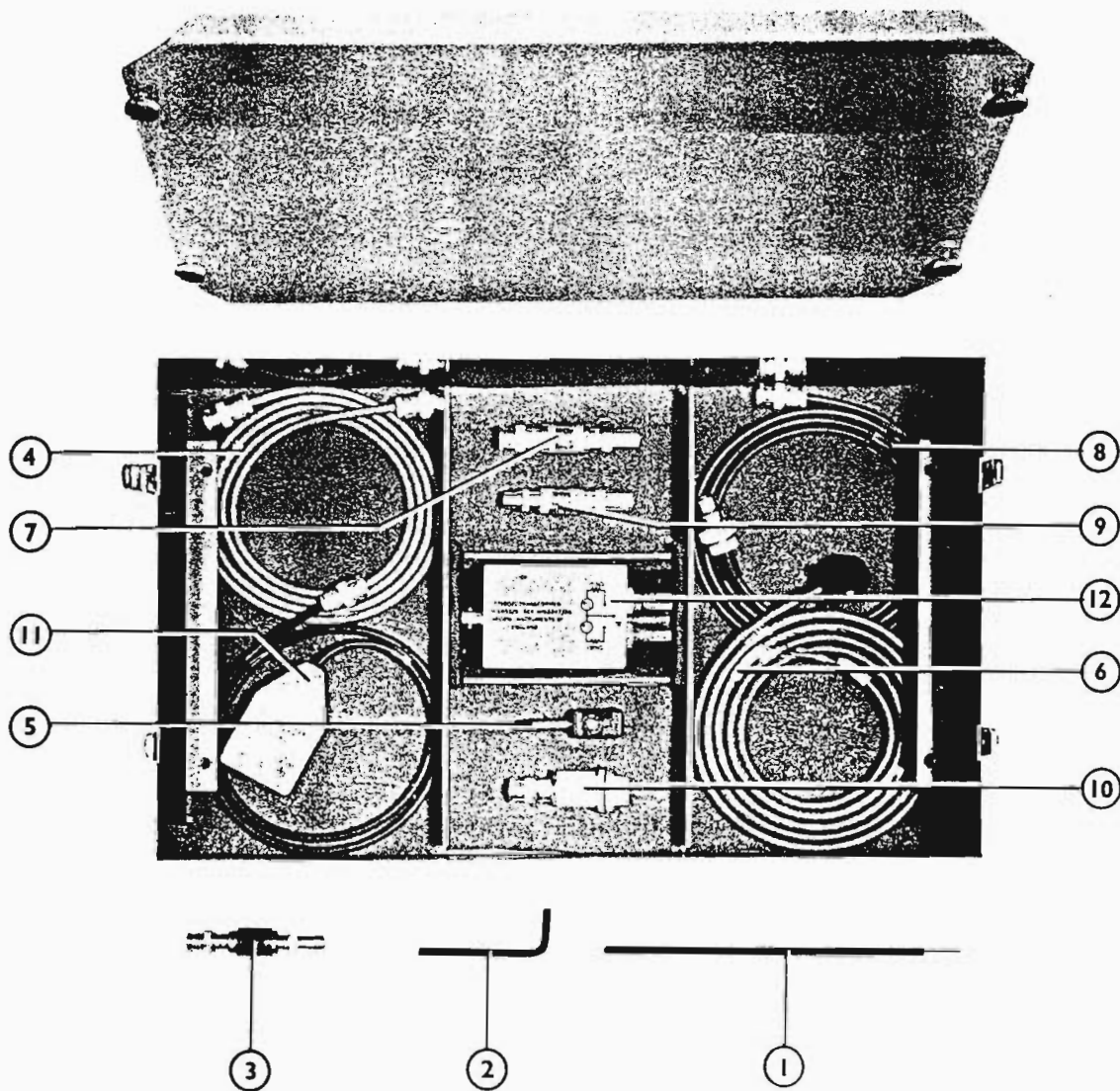

Fig. 1.2 Front panel protection lid and accessories



## 2.1 PREPARATION FOR USE

In common with other apparatus employing semiconductor devices, the performance of the instrument may be affected if it is subjected to excessive temperatures. Therefore completely remove the plastic cover, if one is supplied over the case, and avoid using the instrument standing on, or close to, other equipment that is hot.

### A.C. power supply

Normally the instrument is supplied with the mains selector switch set for supply voltages within the range 190 to 264 V. For input voltages in the range 95 to 130 V the selector switch must be pressed to the left. Do this by removing the plate securing the switch button, pressing the switch to the correct position, reversing the plate and replacing it to hold the switch in the new position. The mains fuse need not be replaced when changing the voltage range.

Attach a suitable 3 pin plug to the mains lead. Note the wires will be colour coded according to one of the following schemes:

Earth (ground)	-	Green/Yellow	Green/Yellow
Neutral	-	Black	Light Blue
Line (phase)	-	Blue	Brown

In addition the earth wire carries a yellow sleeve bearing a green earth symbol and the neutral wire has a sleeve marked N.

Before connecting the supply press the MAINS/BATTERY switch to MAINS.

### D.C. power supply

A d. c. supply of between 19 and 32 V, positive earthed, may be used. The current drain is about 300 mA.

Press the MAINS/BATTERY switch to the position marked BATTERY and connect the supply by leads to the positive and negative terminals at the rear of the instrument.

### Rack mounting

Before inserting TF 2002AS into a rack that would be subjected to any violent movement or vibration, slides or runners must be fitted to the rack to give support to the rear of the instrument as the four retaining screws cannot be relied upon to bear its full weight. A rack mounting kit, TM 8269, can be obtained from the mi Service Division.

### Meter zeroing

Before turning the SUPPLY switch ON check that the pointers of the meters are at their extreme left hand calibration mark (zero scale deflection). If necessary, adjust the set screw at the top of each meter to bring the pointer to this position.

## 2.2 FUSES

Three fuses are fitted to the instrument; two, 0FS1 and 0FS2, protect the power supply circuits and are accessible at the rear of the instrument. The third, 25FS1, is to protect the output transistors of the wide band amplifier from the effects of excessive drive. It may blow if, e. g. , on range H the CARRIER LEVEL meter is set above the -6 dB point, with modulation present, or if excessive level of external d. c. modulation is applied. When using external direct coupled modulation, on ranges A-G, a limiter diode prevents overload.

All the fuses are standard 20 mm x 5 mm components. Suitable replacements are indicated in Table 2.1.

Table 2.1

Fuse	Rating	Type
0FS1	160 mA, time lag	Beswick TDC 123/160 mA
0FS2	500 mA, time lag	Beswick TDC 123/500 mA
25FS1	100 mA, quick acting	Beswick TDC 13/100 mA or Bulgin F271

### 2.3 CONTROLS—supply and tuning

- ① SUPPLY switch. Turn clockwise to switch on.
- ② Main tuning scale. The scale is engraved in a continuous range from 10 kHz to 72 MHz.
- ③ RANGE switch. 8 positions, lettered to correspond to the frequency bands.
- ④ Main FREQUENCY control. The knob skirt carries a logging scale that enables the main tuning scale to be divided into 1000 divisions.
- ⑤ SET SCALE control. Mechanical adjustment of main tuning scale for frequency standardization. A positive index locates the nominal centre position.
- ⑥ INCREMENTAL FREQUENCY control and scale. Provides calibrated frequency shifts up to the limits indicated alongside the control.
- ⑦ SET ZERO control. Sets the frequency of the zero calibration mark of the INCREMENTAL FREQUENCY control ⑥
- ⑧  $\Delta f$  RANGE. Range of incremental tuning
- ⑨ F. M. RANGE. Range of frequency modulation selected by this switch. Range positions as above.
- ⑩ F. M./  $\Delta f$  FINE CAL. Control for increasing the accuracy of the INCREMENTAL FREQUENCY and deviation scale setting. To maintain rated accuracy, control should be central.
- ⑪ CRYSTAL CALIBRATOR selector. Selects the intervals at which marker pips are provided (1 MHz, 100 kHz, 10 kHz). An additional switch position gives a sharp null separated by 1 kHz from each 10 kHz marker.
- ⑫ CRYSTAL CALIBRATOR LEVEL control. Adjusts the a. f. level of the markers.
- ⑬ CRYSTAL CALIBRATION OUTPUT socket. Phones jack, the internal loudspeaker is disconnected when a plug is inserted.
- ⑭ FUNCTION switch. Three internal switch positions: CW, AM, FM; four external switch positions: AM, FM, LEVELLING,  $\Delta f$ .

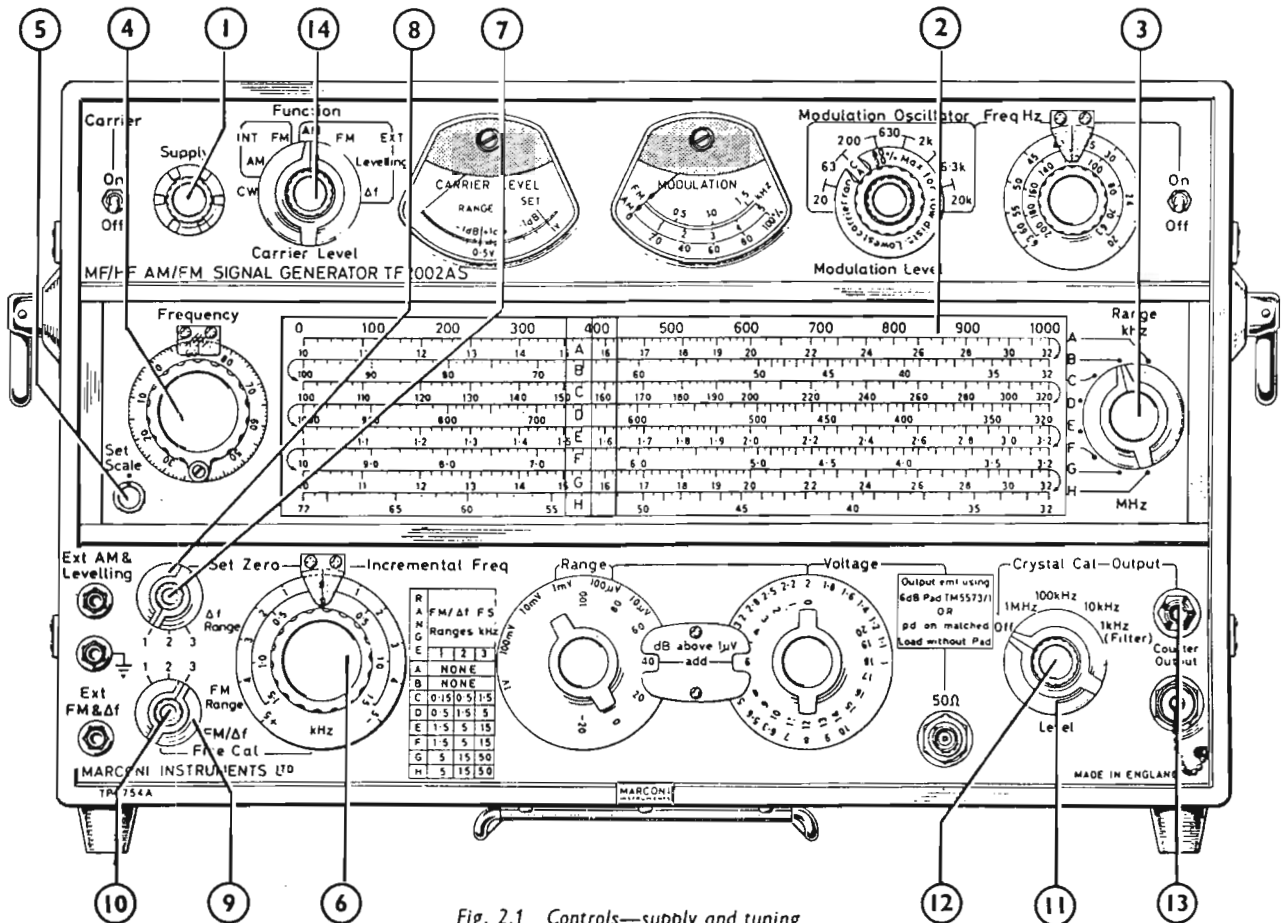

Fig. 2.1 Controls—supply and tuning

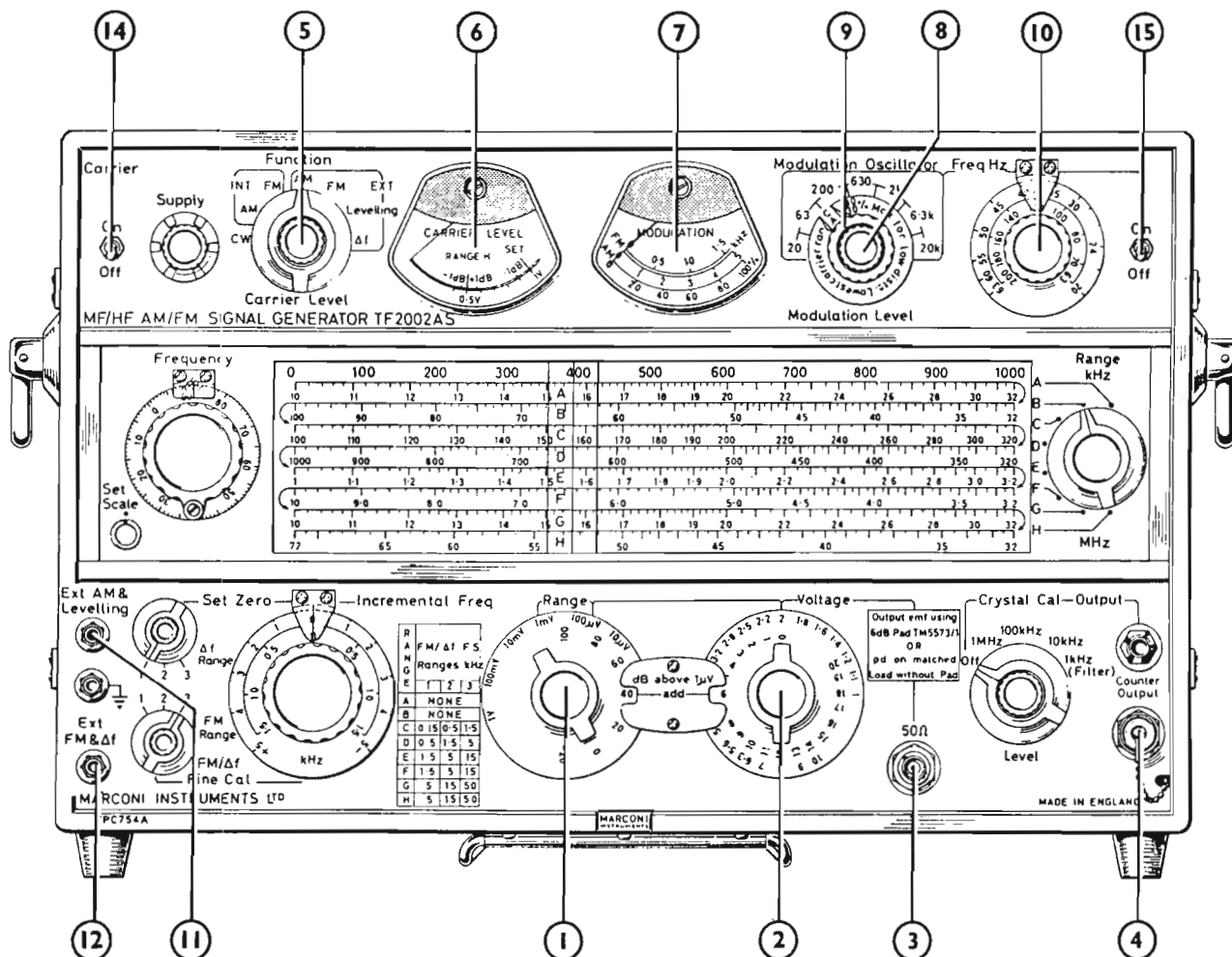

Fig. 2.2 Controls—modulation and output

2.4 CONTROLS—modulation and output

- ① Coarse Attenuator. Six 20 dB steps.
- ② Fine Attenuator. Twenty 1 dB steps.
- ③ R. F. Output Socket. 50 Ω, BNC socket.
- ④ COUNTER OUTPUT. 250 Ω source impedance BNC socket. Output is unmodulated and the level is not controlled; suitable for 50 Ω load.
- ⑤ CARRIER LEVEL control. Sets carrier to standard level indicated by ⑦. May also be used to interpolate between attenuator steps.
- ⑥ CARRIER LEVEL meter. With the pointer at SET the attenuator dials are direct reading in dB above 1 μV. Meter also scaled in volts to assist interpolation.
- ⑦ MODULATION meter. Scaled in percentage modulation depth. Scaled in kHz for f. m. deviation. Ranges 0 - 5 kHz; 0 - 1.5 kHz.

- ⑧ MODULATION LEVEL control. Adjust modulation level of either internal or external f. m. and a. m. modulation signals.
- ⑨ MODULATION OSCILLATOR. Selects internal modulation frequency range.
- ⑩ MODULATION FREQUENCY control and scale. Continuously variable internal modulation frequency control.
- ⑪ EXTERNAL A. M. & LEVELLING. A. C. coupled. Inlet for external amplitude modulating signals. With FUNCTION switch in appropriate position, 'LEVELLING', a -6.75 V potential appears on the terminal and carrier level may be varied by d. c. from a remote position.

**CAUTION** On ranges A to G, outputs in excess of f. s. d. on CARRIER meter are permissible and internally limited to approx. x2 f. s. d. On range H, f. s. d. must not be exceeded.

⑫ EXTERNAL F. M. &  $\Delta f$ . D. C. coupled with a standing -6.75 V potential on the terminal when FUNCTION switch is in EXT  $\Delta f$  position. Inlet for external frequency modulating signals.

⑬  $\Delta f$  LEVELLING NEUTRAL. There are two terminals on the front panel, (EXT/AM, LEVELLING and EXT  $\Delta f$ , F. M) which carry a -6.75 V potential when the FUNCTION switch is in the appropriate position. If it is required to use either of these functions in such a way that the -6.75 V potential does not appear across the drive source, also that the drive source does not shift the mean carrier level or frequency, then the external source may be connected between the appropriate terminal and the rear terminal ⑬.

The  $\Delta f$  LEVELLING NEUTRAL terminal has a standing potential of -6.75 V.

**CAUTION** The source impedance of the -6.75 V potential is very low so that care must be taken to avoid short circuiting this supply. No damage to the instrument will ensue but correct operation will be prevented.

⑭ CARRIER 'ON-OFF' switch. For interruptions of the carrier. Operates in any position of the FUNCTION switch.

⑮ MODULATION 'ON-OFF' switch. For interruptions of internal a. m. or f. m. modulation, by stopping modulation oscillator.

⑯ MODULATION OSCILLATOR OUTPUT. Can be used as a constant sync output for viewing modulation waveforms.

⑰ Battery terminals

⑱ MAINS/BATTERY changeover switch.

⑲ Voltage selector

⑳ Mains Input Socket.

## 2.5 SETTING FREQUENCY

Turn the SUPPLY and the CARRIER 'ON-OFF' switches ON. Although the instrument operates within seconds of switching on, to obtain improved frequency stability allow a stabilizing period of ten minutes or more.

Using the RANGE switch, select the range that includes the desired carrier frequency. The ranges are:

Table 2.2

A	10 - 32 kHz	E	1 - 3.2 MHz
B	32 - 100 kHz	F	3.2 - 10 MHz
C	100 - 320 kHz	G	10 - 32 MHz
D	320 - 1000 kHz	H	32 - 72 MHz

Turn the INCREMENTAL FREQUENCY control to zero and the SET SCALE control to its central index position. Adjust the main FREQUENCY control until the desired frequency is indicated on the main tuning scale.

### Crystal calibrator

Marker points at 1 MHz, 100 kHz or 10 kHz intervals can be chosen by the CRYSTAL CALIBRATOR selector switch. The last position of the switch gives markers at 10 kHz and brings into circuit a 1 kHz rejection filter that gives a null 1 kHz either side of each 10 kHz point.

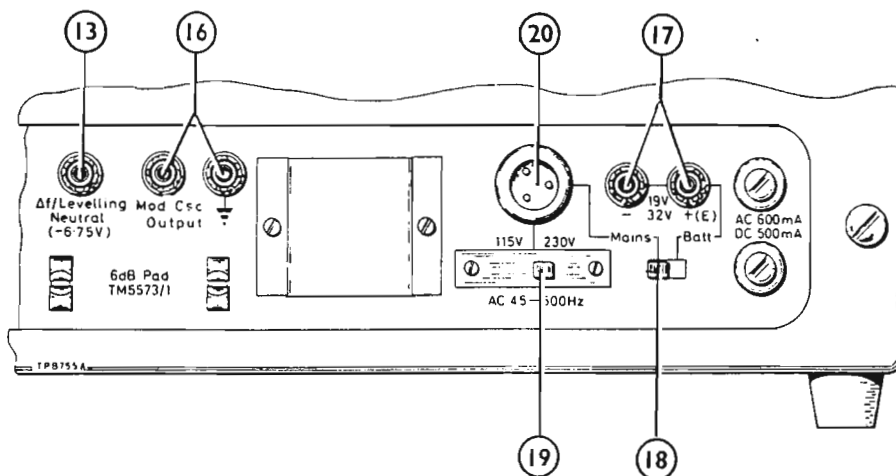

Fig. 2.3 Controls at the rear of the instrument



A loudspeaker is fitted to monitor the crystal calibrator markers, but if greater sensitivity is wanted or it is desired not to disturb other workers, plug a pair of headphones into the CRYSTAL CALIBRATOR OUTPUT socket. Any headphones with an impedance in the range 50  $\Omega$  to 50 k $\Omega$  will be suitable. Switch the calibrator on by putting the CRYSTAL CALIBRATOR selector switch to a position that gives markers at convenient intervals. To avoid ambiguity due to the limitation of the main frequency scale use the following initial settings:

Table 2.3

Frequency range	Crystal calibrator selector setting	Frequency range	Crystal calibrator selector setting
A	10 kHz	E	100 kHz
B	10 kHz	F	1 MHz
C	10 kHz	G	1 MHz
D	100 kHz	H	1 MHz

Tune the signal generator approximately to the marker frequency nearest to the desired carrier frequency and adjust the main FREQUENCY control for zero beat. Bring the beat note amplitude to a convenient level with the CRYSTAL CALIBRATOR LEVEL control (red knob).

If it is wished to standardize the scale, turn the SET SCALE control to bring the scale point corresponding to the crystal marker into coincidence with the cursor.

By switching the CRYSTAL CALIBRATOR selector switch in turn to 100 kHz and 10 kHz

marker intervals, advancing the main FREQUENCY control and counting the marker pips as they are heard, it is possible to set the frequency of the signal generator to any 10 kHz point.

Example 1: To tune the signal generator to a frequency of 4.23 MHz: Switch to RANGE F (3.2 - 10 MHz) and, with the main FREQUENCY control, bring the cursor to 4 MHz on the main tuning scale. Plug in headphones and set the CRYSTAL CALIBRATOR selector to 1 MHz. Slightly adjust the main FREQUENCY control until a marker is heard. Reset the CRYSTAL CALIBRATOR selector to 100 kHz and advance the main FREQUENCY control past the 4.0 MHz marker, then past the 4.1 MHz marker and stop at the 4.2 MHz marker. Reset the CRYSTAL CALIBRATOR selector to 10 kHz and advance the main FREQUENCY control past the first two 10 kHz markers (4.21 and 4.22 MHz) and stop at the zero beat point of the third.

### Incremental tuning

Electrical fine tuning at frequencies above 100 kHz can be obtained with the INCREMENTAL FREQUENCY control. This may be wanted, for example, for precise frequency setting or for accurate bandwidth measurements of < 1%.

The facility to standardize electrical fine tuning with the CRYSTAL CALIBRATOR using Table 2.4, improves INCREMENTAL FREQUENCY control to an accuracy of 5%, (unstandardized accuracy 15%).

The accuracy of f. m. is simultaneously improved by the standardizing procedure.

Table 2.4

To set the INCREMENTAL FREQUENCY control for full scale sensitivity of

	1.5 kHz	5 kHz	15 kHz	50 kHz	
Set CRYSTAL CAL selector to:	1 kHz (Filter)	1 kHz (Filter)	10 kHz	10 kHz	
Set INCREMENTAL FREQUENCY dial to:	+ or - 1 on scale 1.5-0-1.5	+ or - 1 on scale 1.5-0-1.5	+ or - 1 on scale 1.5-0-1.5	+ or - 1 on scale 1.5-0-1.5	+ or - 5 on scale 5-0-5
Adjust F. M. / $\Delta f$ , control until:	First 1 kHz null point found	First 1 kHz null point found	First 10 kHz zero beat found	First 10 kHz zero beat found	Fifth 10 kHz zero beat found
Available on carrier ranges:	C, D, E, F.	D.	E, F, G, H.	E, F, G, H.	G, H.

Tune the signal generator, with the aid of the crystal calibrator if necessary, to a frequency just lower than the range to be investigated. This frequency should be a multiple of 10 kHz.

Two independent front panel controls are provided for setting up the INCREMENTAL FREQUENCY, the SET ZERO control, which gives a fine adjustment enabling the scale zero to be brought to a convenient point, and the F. M./ $\Delta f$  FINE CAL control, which allows the incremental sensitivity to be set up accurately against the CRYSTAL CAL.

The F. M./ $\Delta f$  FINE CAL control has a  $\pm 15\%$  range of the INCREMENTAL FREQUENCY dial. To maintain a rated accuracy, this control should be adjusted to its central position.

To adjust the SET ZERO. Set the CRYSTAL CALIBRATOR selector to 10 kHz and, using either the internal loudspeaker or a pair of headphones plugged into the OUTPUT socket, adjust the SET ZERO control for a zero beat at the nearest 10 kHz marker point, with the INCREMENTAL FREQUENCY dial at zero.

To adjust the F. M.  $\Delta f$  FINE CAL control. Turn the INCREMENTAL FREQUENCY dial until the desired increment is set and adjust the F. M./ $\Delta f$  FINE CAL until the wanted frequency shift, determined by the CRYSTAL CALIBRATOR, has been obtained. The principle settings are summarized in Table 2.4. Whilst it is good practice to set the main frequency control before standardizing the INCREMENTAL FREQUENCY dial, small subsequent adjustments of the main frequency tuning will not substantially affect the standardization of frequency increments on the INCREMENTAL FREQUENCY scale. Where a small difference between positive and negative scale lengths is observed, the scale appropriate to the measurements being made should be standardized.

Example 2.

Tune to 4.23 MHz using the procedure described in Example 1.

The subsequent procedure should be followed to obtain a frequency of 4.2341 MHz.

- † Complete tuning for zero beat with SET ZERO control.
- † \* Advance to 1.0 on inner scale of INCREMENTAL FREQUENCY dial.
- † \* Ensure  $\Delta f$  RANGE is in position 3 (15-0-15 kHz).

- † \* Adjust FINE CAL for zero beat.

INCREMENTAL FREQUENCY dial now standardized.

Switch  $\Delta f$  RANGE to position 2 (5-0-5 kHz).

Adjust INCREMENTAL FREQUENCY dial to 4.1 on outer scale.

\* The frequency could have been obtained with reduced accuracy on last two digits by omitting these procedures.

† These four operations have simultaneously increased the accuracy of the 3 available f. m. scales at this frequency.

External frequency shift

The EXTERNAL FM/  $\Delta f$  terminal may be used for making remote frequency shifts or for phase locking. There is a potential of -6.75 V between the terminal and earth, and the source impedance is 100 k $\Omega$ . The sense of operation is such that an increase of this potential (in the negative direction) increases the carrier frequency.

The limits of frequency shift that may be employed depend on the amount of non-linearity that is acceptable. In general, at the low frequency ends of the carrier ranges the maximum usable excursions are defined by the Table 2.5. (front panel table). At the high frequency end of the ranges, the maximum usable excursions are approximately x3 greater.

Ranges C and D can accept increased drive so that they will provide greater frequency excursions than shown in Table 2.5. Range C will provide at least 2.5 kHz and range D 15 kHz at the low end of the band. At the high frequency end of the bands, the normal x3 increase can be expected.

Table 2.5

As on front panel of instrument

Range	F.M. and $\Delta f$ scale ranges (kHz)		
A	NONE		
B	NONE		
C	0.15	0.5	1.5
D	0.5	1.5	5
E	1.5	5.0	15
F	1.5	5.0	15
G	5.0	15	50
H	5.0	15	50

The voltage at the terminal should not fall outside the limits of -2 V and -11.5 V if severe non-linearity is to be avoided.

The EXT  $\Delta f$  setting of the FUNCTION switch also provides simultaneous internal a. m. The modulation depth may be monitored and adjusted by temporarily setting the FUNCTION switch to the INT AM position. If a c. w. external  $\Delta f$  function is required, the MODULATION LEVEL control must be fully counter clockwise.

### Logging scale

For making incremental shifts on ranges A and B or for making greater shifts than available from the electrical fine tuning circuits on the other carrier ranges the logging scale may be used.

The 0 - 100 scale around the main FREQUENCY control relates to the top scale on the main tuning dial and thus allows each frequency range to be divided into nearly 1000 divisions.

Calibrate the logging scale over a convenient number of divisions corresponding to a frequency change of 10% or less, using the crystal calibrator. Although the frequency scale has a logarithmic type law, linear interpolation by means of the logging scale can be used for a first approximation.

## 2.6 AMPLITUDE MODULATION

### Internal a.m.

To obtain amplitude modulation by the internal oscillator:

- 1) Set the FUNCTION switch to INT. A. M.
- 2) Set the MODULATION OSCILLATOR 'ON-OFF' switch to 'ON'.
- 3) Set the MODULATION OSCILLATOR switch to the position corresponding to the frequency range that includes the required modulating frequency. Each switch position that gives internal modulation falls between two figures, which indicate in Hz the frequency limits of the band obtained at that position.
- 4) Turn the MODULATION FREQUENCY control so that the dial indicates the required frequency.
- 5) Advance the MODULATION LEVEL control (red knob) until the MODULATION METER shows the required percentage modulation. The maximum depth for low distortion modulation is limited

when the modulation frequency exceeds a certain percentage of the carrier frequencies. Table 1.1 gives the maximum modulating frequencies for 5% distortion at 80% modulation depth.

The MODULATION OSCILLATOR knob also shows the lowest carrier ranges that can be used with low distortion for each modulating frequency range at 30% and 80% modulation depth.

When the MODULATION OSCILLATOR 'ON-OFF' switch is 'ON', the modulation frequency is available at the MODULATION OSCILLATOR OUTPUT terminals at the rear of the instrument. This output is independent of the function switch position.

This may be used, for example, to synchronize an oscilloscope at the modulation frequency. The output level is about 1 V r. m. s. and the source impedance 10 k $\Omega$ .

### External a.m. (a.c. coupled)

Turn the FUNCTION switch to EXT A. M. Apply an a. c. modulating signal between the EXT A. M. LEVELLING terminal and earth. Set the MODULATION LEVEL control to give the required percentage modulation indicated on the MODULATION meter.

NOTE: As the modulation meter is a peak detector, non-sinusoidal modulating signals may be used without introducing over-modulation. The input required is about 1 V r. m. s. into 700  $\Omega$  minimum for full modulation.

For high modulating frequencies the modulation depth limitations, given above for internal modulation, must be observed.

### External levelling (direct coupled)

For low audio-frequency modulation with very low phase shift, or sub-audio modulation, direct coupling to the modulating circuit is available. The facility may also be useful for remote level adjustment either manual or automatic.

Turn the FUNCTION selector to EXT LEVELLING. In this position a standing potential of -6.75 V appears between the EXT A. M. LEVELLING terminal and earth. To avoid developing this direct voltage across any drive source, and change in mean carrier level, connection may be made between EXT A. M. LEVELLING and the -6.75 V neutral terminal, (marked  $\Delta f$ /LEVELLING NEUTRAL), provided at the rear of the instrument.

This may be used to control the carrier amplitude in three ways:

- 1) An adjustable shunt resistor may be used to raise the carrier level. The value may be adjusted down to zero from ranges A to G, when maximum available output may be developed. On range H, 25 k $\Omega$  is minimum value that may be used.

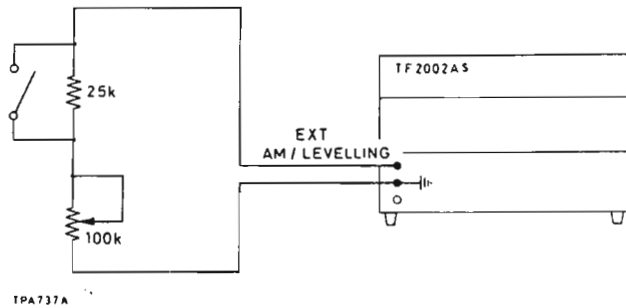

Fig. 2.4 External passive amplitude control circuit

- 2) By applying a direct or alternating potential from a high impedance source. The sensitivity is such that approximately -12 V will reduce the carrier to zero and 0 V will produce maximum available output except on range H when the applied potential should not be reduced lower than -3 V.

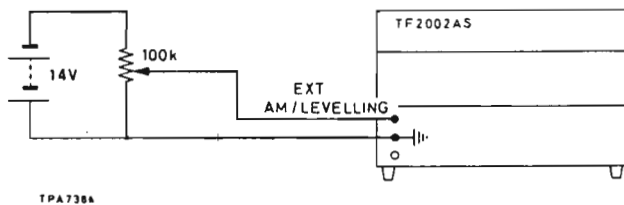

Fig. 2.5 External amplitude control circuit

- 3) By applying a two-terminal floating, direct or alternating potential between EXT A. M. LEVELLING terminal and the  $\Delta f$ /LEVELLING NEUTRAL terminal at the rear of the instrument. Fig. 2.6 shows a balanced direct source but an

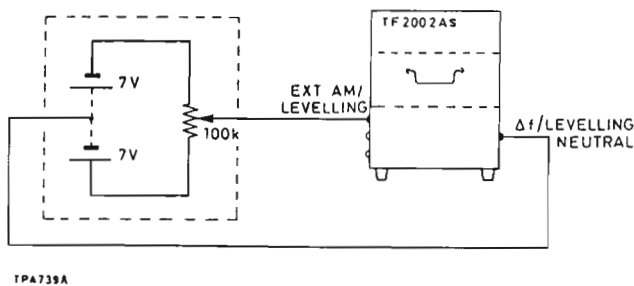

Fig. 2.6 External balanced drive source

alternating drive could be used in place of the circuit enclosed in the dotted area.

The MODULATION LEVEL control does not operate in this position but the CARRIER LEVEL meter is operative.

For high modulating frequencies, the modulation level limitations, given above for internal modulation, must be observed.

## 2.7 FREQUENCY MODULATION

Frequency modulation is possible only on carrier frequencies upwards of 100 kHz. Modulation frequencies up to 20 kHz are available except between 100 kHz and 1 MHz, when 4 kHz is the maximum for the rated accuracy. Frequency shifts may be applied together with frequency modulation but take care to avoid over modulation. At the low frequency end of each carrier range the sum of the applied shifts and the peak f. m. deviation must not take the frequency outside the limits given in the front panel table.

To obtain Frequency modulation by the internal oscillator:

- 1) Set the MODULATION OSCILLATOR 'ON-OFF' switch to 'ON'.
- 2) Set the FUNCTION switch to INT F. M.
- 3) Set the MODULATION OSCILLATOR switch to the position corresponding to the frequency range that includes the required modulating frequency.
- 4) Turn the MODULATION FREQUENCY control so that the dial indicates the required frequency.
- 5) Select suitable F. M. RANGE switch setting from table on front panel.
- 6) Advance the MODULATION LEVEL control (red knob) until the MODULATION meter shows the required deviation.

The unstandardized accuracy of the f. m. is 15% (with the FINE CAL control central) and 5% when the accuracy is improved by calibrating the INCREMENTAL fine tuning dial against internal Crystal calibrator.

When  $\Delta f$  standardizing procedure is carried out for any one carrier frequency, the f.m. accuracy is simultaneously standardized.

The f.m. meter scale may be expanded in positions 2 and 1, when the improved accuracy is maintained.

**External frequency modulation (a.c. coupled)**

Set the FUNCTION switch to EXT F. M.

Apply a.c. modulating signal between EXT  $\Delta f$  F. M. terminal and earth terminal.

Set MODULATION LEVEL control and F. M. RANGE switch to give required deviation indicated on the MODULATION meter.

The input required is approximately 1 V r. m. s. into 2.5 k $\Omega$  for full scale deflection on meter.

Since the MODULATION meter is a peak detector, non-sinusoidal modulating signals may be used without introducing a reading error.

The maximum deviation available is detailed in Table 2.5. Provided the incremental fine tuning system has been standardized at a given carrier frequency, the f.m. monitor circuit will read accurately within 5% for external signals.

**External  $\Delta f$  (d.c. coupled)**

This feature can be used for a low modulating frequency, f.m. facility, external frequency shift, manual or automatic frequency control, phase modulation or sweeping; direct coupling to the modulation circuit is available.

When FUNCTION switch is set to EXT  $\Delta f$  a standing -6.75 V potential appears on the EXT  $\Delta f$  terminal. To avoid developing this direct voltage across any drive source, and change in mean carrier frequency, connection may be made between EXT  $\Delta f$  F. M. and the -6.75 V neutral terminal, (marked  $\Delta f$ /LEVELLING NEUTRAL), provided at the rear of the instrument.

The tracking network used to compensate the variable sensitivity of each frequency modulator over a given carrier range, is not used in the EXT  $\Delta f$  position. Therefore the maximum possible frequency shift is obtained but the deviations thus obtained are neither monitored nor constant.

Sensitivity at the high frequency end of each range is x3 greater than at the low frequency end.

The following three diagrams show the ways of controlling the carrier frequency:

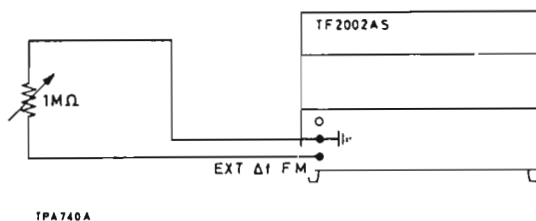

Fig. 2.7 Passive external frequency control

This network can be used only for downward changes in frequency.

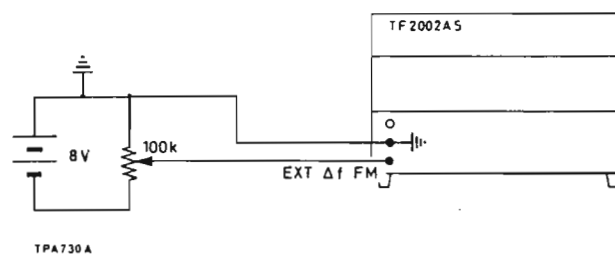

Fig. 2.8 External unbalanced source

This circuit may be used for positive or negative increments of the carrier frequency.

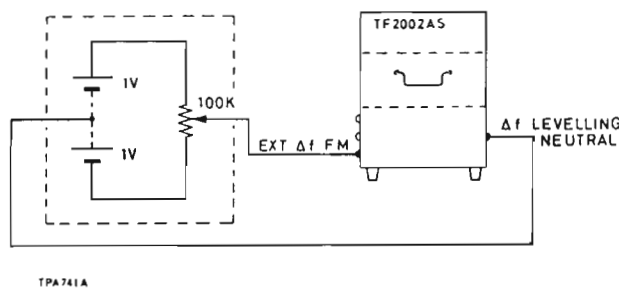

Fig. 2.9 External balanced source

This network can also be used for increases or decreases of incremental frequency; frequency shift is proportional to the voltage input, i.e. 0 V input would mean no frequency shift.

An alternating drive could be used in place of the circuit enclosed in the dotted area.

**2.8 SETTING OUTPUT**

Turn the CARRIER switch to ON and bring the pointer of the CARRIER LEVEL meter to the SET mark (1 V) by adjusting the CARRIER LEVEL control.

Note: With a modulated carrier on range H the CARRIER LEVEL meter should be set to the RANGE H MODULATED mark (0.5 V).

Adjustment of the CARRIER LEVEL control can be made without affecting the modulation depth. Turn the coarse and fine output attenuator controls until the desired output is indicated.

The output levels read from the attenuator dials are those which appear across a matching (50 Ω) load. The attenuators are also direct reading in terms of source e. m. f. when the output is fed through the 6 dB pad TM 5573/1. This pad is normally stowed at the rear of the instrument.

**Expressed in dB referred to 1 μV**

With the CARRIER LEVEL meter at SET, the output level is the sum of the readings of the dB scales of the coarse and fine attenuators. The fine attenuator allows level adjustment in 1 dB steps but intermediate outputs can be obtained by varying the setting of the CARRIER LEVEL control.

If the CARRIER LEVEL meter is at RANGE H MODULATED, subtract 6 dB from the output indicated by the attenuator dials.

**Expressed in volts**

With the CARRIER LEVEL meter at 1 V the output voltage is indicated on the fine attenuator dial within the decade shown on the coarse attenuator dial. If the CARRIER LEVEL meter is at 0.5 V the output is half that indicated by the attenuator dials.

**Counter output**

For applications such as operating a counter type frequency meter, an alternative output is provided. This output is unmodulated and the level is not affected by the CARRIER LEVEL control or the attenuators. The output e. m. f. is about 200 mV and the source impedance 250 Ω. It will satisfactorily operate equipment with a 50 Ω input.

**2.9 MISMATCHED LOADS**

The r. f. output circuit of the signal generator should be regarded as a zero impedance voltage source in series with a resistance of 50 Ω. This is shown in Fig. 2.10 where:

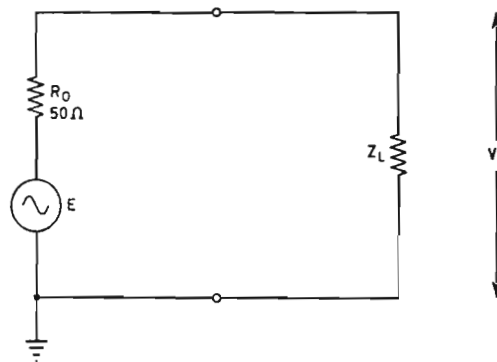

Fig. 2.10 Equivalent output circuit

- E is the indicated source e. m. f.,
- $R_o$  is the source resistance,
- $Z_L$  is the external load impedance,
- $V_L$ , the voltage developed across the load is given by

$$V_L = E \frac{Z_L}{R_o + Z_L}$$

or, for purely resistive loads

$$V_L = E \frac{R_L}{R_o + R_L}$$

Table 2.6 shows the conversion factors for obtaining the load voltage from the indicated e. m. f. at different load impedances.

Table 2.6

To find load voltage:

Load ohms	Multiply e.m.f. by	or subtract dB
10	0.167	15.5
20	0.286	10.9
30	0.375	8.5
40	0.445	7.0
50	0.50	6.0
60	0.55	5.2
70	0.58	4.7
75	0.60	4.4
80	0.62	4.2

Continued

TABLE 2.6 continued

Load ohms	Multiply e.m.f. by	or subtract dB
90	0.64	3.8
100	0.67	3.5
120	0.71	3.0
150	0.75	2.5
200	0.80	1.9
300	0.86	1.3
500	0.91	0.8
600	0.92	0.7
800	0.94	0.5
1000	0.95	0.4
2000	0.98	0.2
4000	0.99	0.1

When using a correctly matched, i. e. 50 Ω output lead, its output end can be regarded as an extension to the output socket on the generator, and wide variations of load impedance do not seriously affect the calculated load voltage obtained from Table 2.6. Standing waves produced by the mismatched load can, for most purposes, be ignored.

For greatest accuracy - if the additional attenuation can be tolerated - use a 20 dB attenuator pad such as type TM 5573 between seriously mismatched loads and the output lead. This ensures that the lead is correctly terminated, and also attenuates any extraneous noise induced in the lead.

**Matching to high impedance loads**

To present a load that is greater than 50 Ω with a signal derived from a matched source, a resistor  $R_S$  is added in series with the generator output. The value of  $R_S$  is given by the difference between the load and the generator impedances, that is

$$R_S = R_L - R_O$$

The voltage across the load,  $V_L$ , is given by

$$V_L = \frac{E}{2}$$

For the special case of a 75 Ω load, matching pads types TM 5569 or TM 6599, are available as

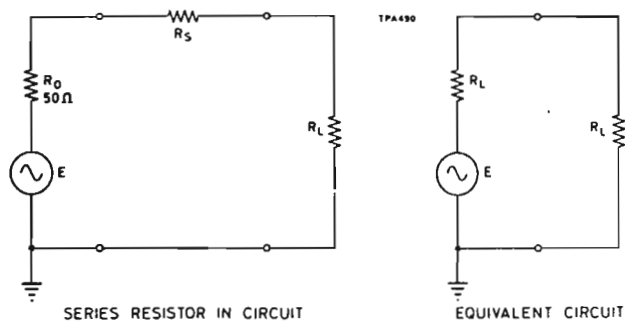

Fig. 2.11 High impedance matching

accessories and consist basically of a 25 Ω resistor with coaxial connectors for insertion in series with the output lead.

If the load impedance is substantially greater than 50 Ω the maximum output may not be available with full modulation. See Data Summary.

**Matching to low impedance loads**

To present a load that is less than 50 Ω with a signal derived from a matched source, a resistor  $R_p$  is added in parallel with the generator output. The value of  $R_p$  is given by

$$R_p = \frac{R_O R_L}{R_O - R_L}$$

The effective source e. m. f. is now different and is given by

$$E_1 = E \frac{R_p}{R_O + R_p}$$

and the voltage across the load,  $V_L$ , is given by

$$V_L = \frac{E_1}{2}$$

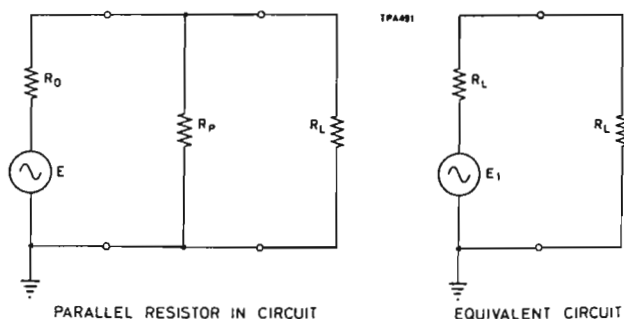

Fig. 2.12 Low impedance matching

### Matching to balanced loads

Equipment whose input circuit is in the form of a balanced winding can be fed from the generator by using two series resistors as shown in Fig. 2.13. This method makes use of the auto-transformer effect of the centre-tapped winding and is not suitable for resistive balanced loads.

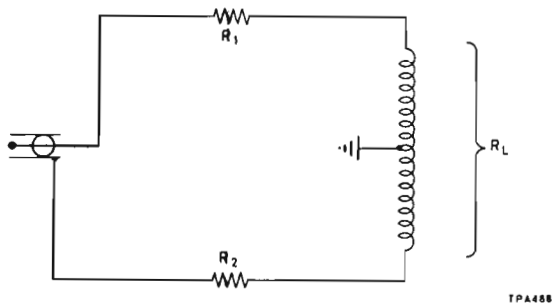

Fig. 2.13 Balanced load matching

The values of  $R_1$  (for use in the centre conductor) and  $R_2$  (for the earth lead) are given by

$$R_1 = \frac{R_L}{2} - 50$$

$$R_2 = \frac{R_L}{2}$$

For use with circuits that have a balanced impedance of  $300 \Omega$  a special matching unit is available as an accessory and may be ordered

under the type number TM 5955/5. It incorporates a wide band transformer with a 1:4 impedance ratio and a resistive pad to give an overall ratio of 1:6. The voltage ratio is  $1:0.5 + 0.5$ .

### 2.10 USE OF DUMMY AERIAL AND D.C. ISOLATOR

To use this dual-purpose unit as a dummy aerial, connect the EMF/10 and E terminals to the receiver under test. The unit then simulates the impedance of a typical aerial for broadcast receivers in the l.f., m.f. and h.f. bands, and provides an output voltage of one-tenth of that indicated by the attenuator dials.

To use it as a 350 V d.c. isolator connect the EMF/2 and E terminals to the equipment under test. This allows the signal generator output to be applied to circuits having a standing d.c. potential up to 350 V. The output voltage is half of that indicated by the attenuator dials.

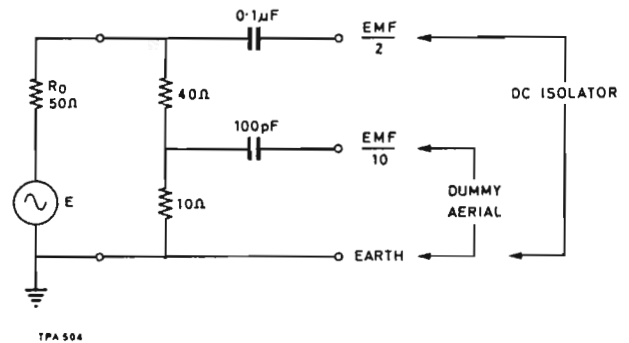



Fig. 2.14 Generator output using TM 6123



## DECIBEL CONVERSION TABLE

<i>Ratio Down</i>			<i>Ratio Up</i>		
VOLTAGE	POWER	DECIBELS	VOLTAGE	POWER	
1.0	1.0	0	1.0	1.0	
·9886	·9772	·1	1.012	1.023	
·9772	·9550	·2	1.023	1.047	
·9661	·9333	·3	1.035	1.072	
·9550	·9120	·4	1.047	1.096	
·9441	·8913	·5	1.059	1.122	
·9333	·8710	·6	1.072	1.148	
·9226	·8511	·7	1.084	1.175	
·9120	·8318	·8	1.096	1.202	
·9016	·8128	·9	1.109	1.230	
·8913	·7943	1.0	1.122	1.259	
·8710	·7586	1.2	1.148	1.318	
·8511	·7244	1.4	1.175	1.380	
·8318	·6918	1.6	1.202	1.445	
·8128	·6607	1.8	1.230	1.514	
·7943	·6310	2.0	1.259	1.585	
·7762	·6026	2.2	1.288	1.660	
·7586	·5754	2.4	1.318	1.738	
·7413	·5495	2.6	1.349	1.820	
·7244	·5248	2.8	1.380	1.905	
·7079	·5012	3.0	1.413	1.995	
·6683	·4467	3.5	1.496	2.239	
·6310	·3981	4.0	1.585	2.512	
·5957	·3548	4.5	1.679	2.818	
·5623	·3162	5.0	1.778	3.162	
·5309	·2818	5.5	1.884	3.548	
·5012	·2512	6	1.995	3.981	
·4467	·1995	7	2.239	5.012	
·3981	·1585	8	2.512	6.310	
·3548	·1259	9	2.818	7.943	
·3162	·1000	10	3.162	10.000	
·2818	·07943	11	3.548	12.59	
·2512	·06310	12	3.981	15.85	
·2239	·05012	13	4.467	19.95	
·1995	·03981	14	5.012	25.12	
·1778	·03162	15	5.623	31.62	

Continued 

**DECIBEL CONVERSION TABLE (continued)**

Ratio Down			Ratio Up	
VOLTAGE	POWER	DECIBELS	VOLTAGE	POWER
.1585	.02512	<b>16</b>	6.310	39.81
.1413	.01995	<b>17</b>	7.079	50.12
.1259	.01585	<b>18</b>	7.943	63.10
.1122	.01259	<b>19</b>	8.913	79.43
.1000	.01000	<b>20</b>	10.000	100.00
.07943	$6.310 \times 10^{-3}$	<b>22</b>	12.59	158.5
.06310	$3.981 \times 10^{-3}$	<b>24</b>	15.85	251.2
.05012	$2.512 \times 10^{-3}$	<b>26</b>	19.95	398.1
.03981	$1.585 \times 10^{-3}$	<b>28</b>	25.12	631.0
.03162	$1.000 \times 10^{-3}$	<b>30</b>	31.62	1,000
.02512	$6.310 \times 10^{-4}$	<b>32</b>	39.81	$1.585 \times 10^3$
.01995	$3.981 \times 10^{-4}$	<b>34</b>	50.12	$2.512 \times 10^3$
.01585	$2.512 \times 10^{-4}$	<b>36</b>	63.10	$3.981 \times 10^3$
.01259	$1.585 \times 10^{-4}$	<b>38</b>	79.43	$6.310 \times 10^3$
.01000	$1.000 \times 10^{-4}$	<b>40</b>	100.00	$1.000 \times 10^4$
$7.943 \times 10^{-3}$	$6.310 \times 10^{-5}$	<b>42</b>	125.9	$1.585 \times 10^4$
$6.310 \times 10^{-3}$	$3.981 \times 10^{-5}$	<b>44</b>	158.5	$2.512 \times 10^4$
$5.012 \times 10^{-3}$	$2.512 \times 10^{-5}$	<b>46</b>	199.5	$3.981 \times 10^4$
$3.981 \times 10^{-3}$	$1.585 \times 10^{-5}$	<b>48</b>	251.2	$6.310 \times 10^4$
$3.162 \times 10^{-3}$	$1.000 \times 10^{-5}$	<b>50</b>	316.2	$1.000 \times 10^5$
$2.512 \times 10^{-3}$	$6.310 \times 10^{-6}$	<b>52</b>	398.1	$1.585 \times 10^5$
$1.995 \times 10^{-3}$	$3.981 \times 10^{-6}$	<b>54</b>	501.2	$2.512 \times 10^5$
$1.585 \times 10^{-3}$	$2.512 \times 10^{-6}$	<b>56</b>	631.0	$3.981 \times 10^5$
$1.259 \times 10^{-3}$	$1.585 \times 10^{-6}$	<b>58</b>	794.3	$6.310 \times 10^5$
$1.000 \times 10^{-3}$	$1.000 \times 10^{-6}$	<b>60</b>	1,000	$1.000 \times 10^6$
$5.623 \times 10^{-4}$	$3.162 \times 10^{-7}$	<b>65</b>	$1.778 \times 10^3$	$3.162 \times 10^6$
$3.162 \times 10^{-4}$	$1.000 \times 10^{-7}$	<b>70</b>	$3.162 \times 10^3$	$1.000 \times 10^7$
$1.778 \times 10^{-4}$	$3.162 \times 10^{-8}$	<b>75</b>	$5.623 \times 10^3$	$3.162 \times 10^7$
$1.000 \times 10^{-4}$	$1.000 \times 10^{-8}$	<b>80</b>	$1.000 \times 10^4$	$1.000 \times 10^8$
$5.623 \times 10^{-5}$	$3.162 \times 10^{-9}$	<b>85</b>	$1.778 \times 10^4$	$3.162 \times 10^8$
$3.162 \times 10^{-5}$	$1.000 \times 10^{-9}$	<b>90</b>	$3.162 \times 10^4$	$1.000 \times 10^9$
$1.000 \times 10^{-5}$	$1.000 \times 10^{-10}$	<b>100</b>	$1.000 \times 10^5$	$1.000 \times 10^{10}$
$3.162 \times 10^{-6}$	$1.000 \times 10^{-11}$	<b>110</b>	$3.162 \times 10^5$	$1.000 \times 10^{11}$
$1.000 \times 10^{-6}$	$1.000 \times 10^{-12}$	<b>120</b>	$1.000 \times 10^6$	$1.000 \times 10^{12}$
$3.162 \times 10^{-7}$	$1.000 \times 10^{-13}$	<b>130</b>	$3.162 \times 10^6$	$1.000 \times 10^{13}$
$1.000 \times 10^{-7}$	$1.000 \times 10^{-14}$	<b>140</b>	$1.000 \times 10^7$	$1.000 \times 10^{14}$

Each of the printed boards and other sub-assemblies in this instrument has been allocated a unit identification number in the sequence ① to ⑳ which, wherever practicable, is marked upon it. The complete circuit reference for a component carries its unit number as a prefix, e.g. 6R15. Components that do not form part of any sub-assembly carry the prefix 0, e.g. 0R6.

For convenience in this chapter and on the circuit diagrams, the circuit reference is abbreviated by dropping the prefix, except where there is a risk of ambiguity.

### 3.1 CIRCUIT SUMMARY

Each carrier frequency range has completely separate oscillator and output filter circuits.

The oscillator and output filter circuits are tuned by ferrite cores moving inside the coil former. Each core drives the required linear motion from a tape attached to a drum.

Alternate ranges are coupled to tapes wound in opposite way around the drum. The frequency of successive ranges thus alternately increases and decreases with one direction of rotation of the FREQUENCY control. This system, which is illustrated in Fig. 3.1 allows a boustrophedon tuning scale to be used.

Range changing is carried out by the wafer switch SG. Power supplies to the oscillators are switched by SG4F and the low level oscillator output to the wide band amplifier by SG2F. SG7F and SG8F switch the wide band amplifier output to the output filter while SG6F switches the filtered signal to the attenuators.

All except the two lowest frequency oscillators have a voltage-controlled capacitive reactance for fine tuning and frequency modulation. The controlling voltage is derived from a composite network connected to the -13.5 V regulated supply and is routed by SG3F to the appropriate oscillator.

Constant output level is maintained by sampling, comparison and error correction. The

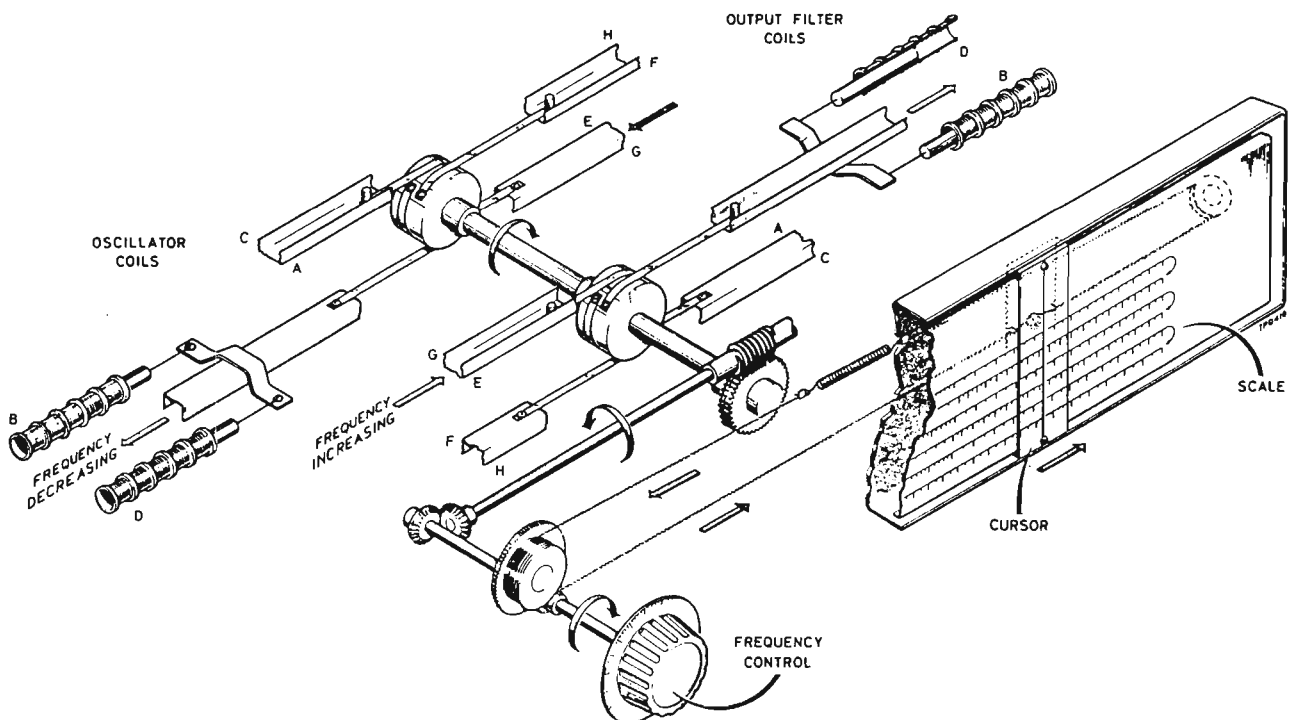

Fig. 3.1 Tuning drive system

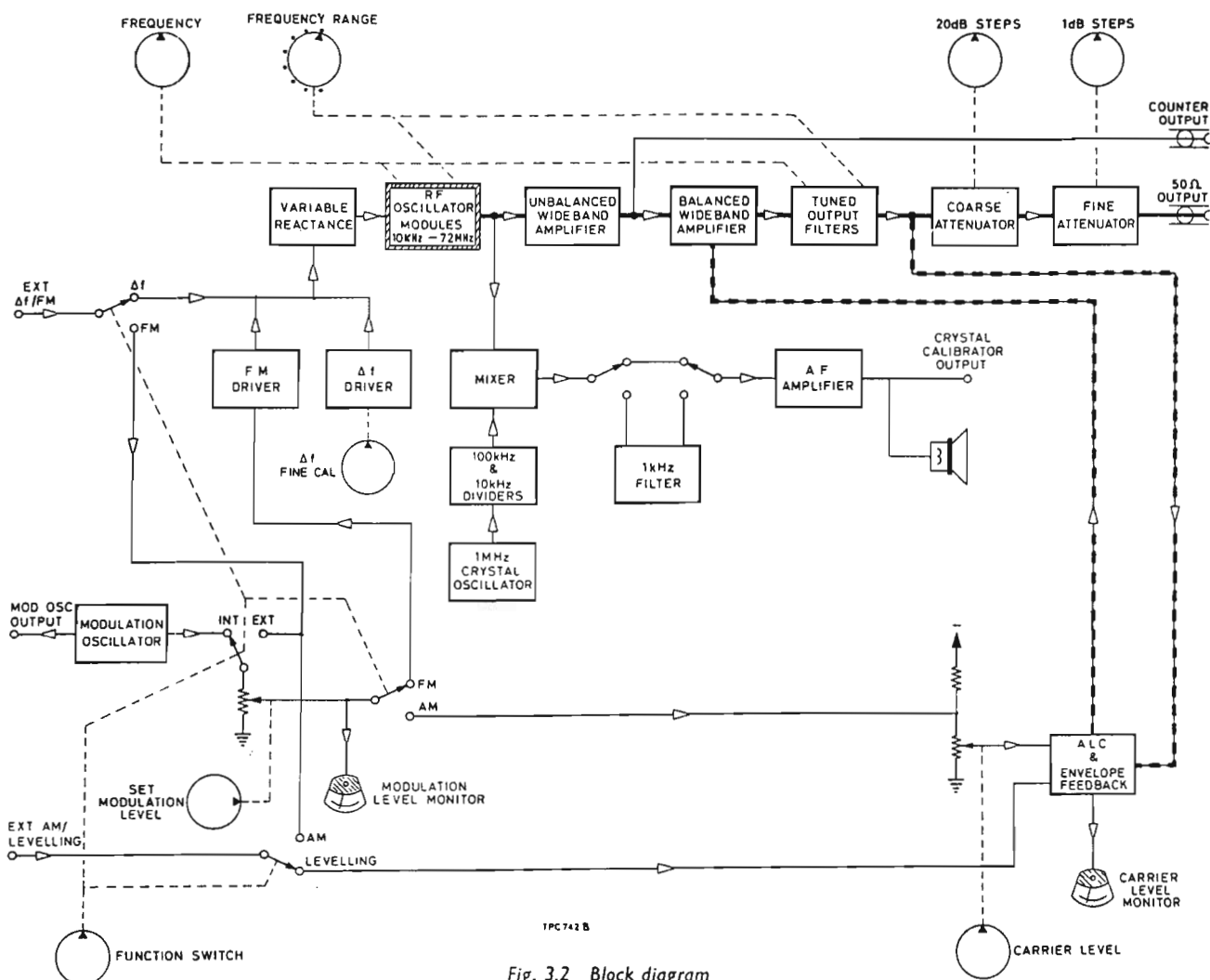

Fig. 3.2 Block diagram

a. l. c. and envelope feedback circuit produces the error signal to control the gain of the wide band amplifier. The modulating signal derived from the modulation oscillator is effectively superimposed upon the error signal and modulates the r. f. signal in the wide band amplifier.

The crystal calibrator mixes the unmodulated r. f. signal with a pulse train derived from a 1 MHz crystal oscillator, giving audible marker points at closely spaced intervals.

### 3.2 CARRIER OSCILLATORS

Circuit diagram—Fig. 7.2

All the oscillators are basically the same; a Colpitts circuit is rearranged to give a  $\pi$  configuration. In each instance tuning is carried out by variation of inductance. The principal inductor of each circuit has a ferrite core whose position in the coil is controlled by the main tuning drive. The series trimmer inductor sets the overall coverage of each range.

Considering the circuit for ranges A and B; a pnp transistor is used with the emitter tapped into the junction of C2 and C3; R5 serves as the collector return to supply whilst R3 shunts part of the tuned circuit to modify its Q.

Ranges C, D, E and F use a silicon npn transistor, VT2, as the oscillator. Its collector earth return has a resistance of approximately 50  $\Omega$  derived from the star terminating network; 25R1, 25R2, 25R3 at the input of the wide band amplifier. VT1 is a reactance transistor connected across the tuned circuit. As a result of the feedback components C2 and R1, the transistor appears as a capacitive reactance whose value is controlled by the base voltage.

For ranges G and H a buffer transistor, VT2, is added and the reactance transistor circuit has been displaced by varactor MR1 to obtain variable capacitive reactance for the incremental tuning and f. m. facility

The buffer is arranged in the common base configuration. Both VT1 and VT2 share the same base bias network; R2, R6 and R3.

### 3.3. WIDE BAND AMPLIFIER

Circuit diagram—Fig. 7.3

Besides amplifying the signal from the low level delivered by the oscillators to the required output level, the wide band amplifier applies the modulating and level control signals.

The input signal from SG2F is applied to the star network R1, R2, R3 which acts as a splitter network passing through part of the signal to the crystal calibrator and the remainder to the wide band amplifier, whilst providing a matching termination to both 50 Ω lines. VT1 and VT2 constitute a two-stage unbalanced amplifier with negative feedback applied across R8 and the partially bypassed emitter resistor R6.

T1 acts as a phase splitter providing a balanced input to the bases of VT3 and VT4. To achieve the necessary bandwidth the transformer is wound bifilarly so that the winding represents constant impedance transmission line. The core is a toroid of ferrite material. Fig. 3.3 shows the transformer redrawn in transmission line form.

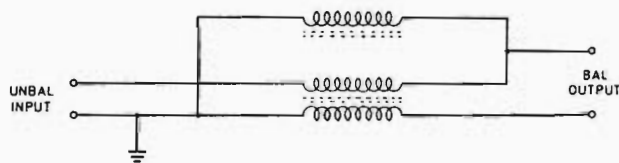

TRANSMISSION LINE FORM

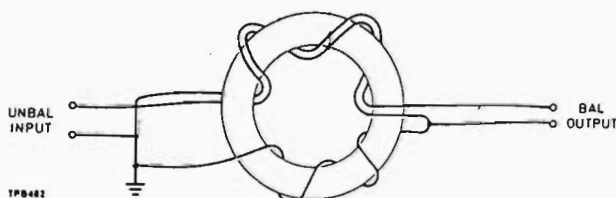

WIRING DIAGRAM

Fig. 3.3 25T1

VT3 and VT4 form the first balanced amplifier stage and the output is coupled via the centre-tapped choke T2 into the second balanced stage VT5

and VT6. It is to this stage that the modulating drive signal, together with automatic level control, is applied. The modulating signal takes the form of a current drive applied to the emitter of VT5 and VT6 and results in a modulation depth of up to 55%.

The modulated signal is coupled to the output stage by T3 at low frequencies and by C12 and C13 at higher frequencies. Frequency compensated feedback is applied by R23 and R24 by using the inherent inductance of these wire wound resistors. No bias is applied to the output transistors VT7 and VT8 which, for silicon transistors, produces a quiescent condition beyond collector current cut-off. This class C operation results in a transfer characteristic that has an initial region with no output (the cut-off condition) but is substantially linear for the remainder.

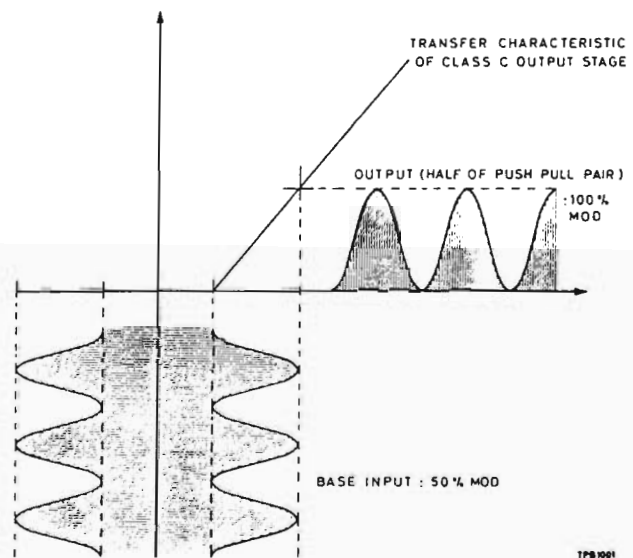

Fig. 3.4 Modulation deepening process

The application of a modulated signal to a push-pull stage having this characteristic gives an effective increase of the modulation depth by a factor of approximately two. The process is shown in Fig. 3.4.

Two output transformers are used; T5 for ranges A to D and T4 for ranges E to H. Each has an impedance transformation of 1:4, balanced to unbalanced. Both transformers have bifilar windings which act as transmission lines, T5 being wound on a pot core and T4 on a ferrite toroid. Fig. 3.5 shows the transformers redrawn in transmission line form.

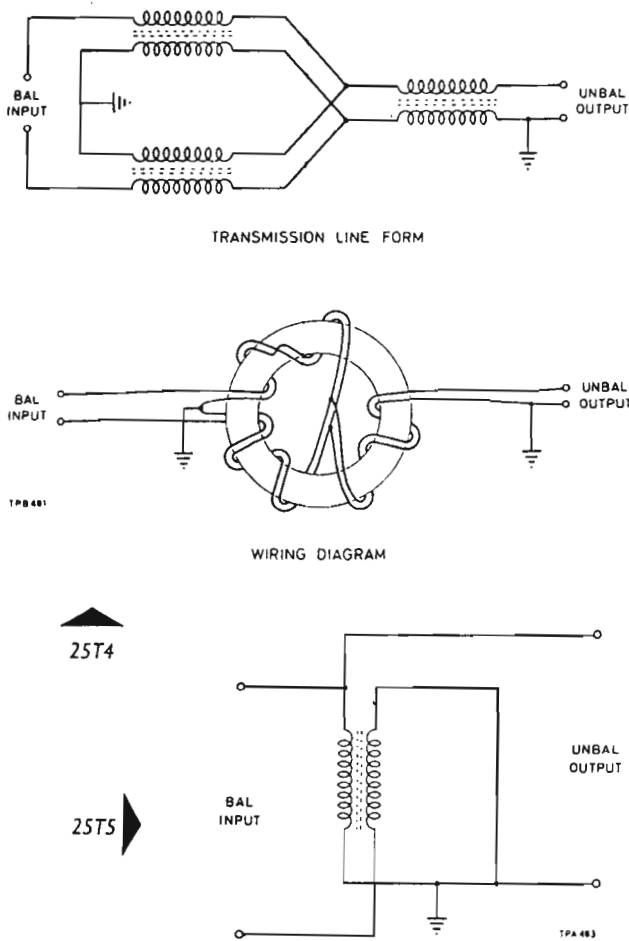

Fig. 3.5 25T4 and 25T5

### 3.4 OUTPUT FILTERS

Circuit diagram—Fig. 7.4

All the carrier filters are similar, consisting primarily of a  $\pi$  tuned circuit with a variable permeability inductor, coupled to the r. f. tuning drive.

Considering the range D circuit as typical, the  $\pi$  tuned filter is made up of the variable inductor L3 in series with the trimmer inductor L2, together with C1, C2 and C3. C4 and L1 constitute a high-pass filter to reject the audio frequency modulation components that would otherwise pass the  $\pi$  output circuit.

### 3.5 A.L.C. AND ENVELOPE FEEDBACK

Circuit diagram—Fig. 7.5

To maintain constant output level and to achieve minimum envelope distortion of a modulated carrier, the circuit compares the output from the wide band amplifier with the modulating and carrier level control signals.

The audio drive plus the d. c. signal from the CARRIER LEVEL control form the instruction signal applied to VT1 which operates as a phase splitter giving balanced outputs to the emitter followers VT4 and VT5. R. F. derived from the output of the wide band amplifier is detected by the bridge, MR3, MR4, R30 and R31, which gives a balanced output with a d. c. component proportional to carrier level and an a. f. component proportional to the modulation depth. This is the reference signal.

These signals are added algebraically by the bridge R20, R22, R18 and R24 and the corresponding difference thus produced, is the composite d. c. + a. f. control signal that is used to modulate the wide band amplifier. The balanced control signal is applied between the bases of VT2 and VT6, which are connected as a long-tailed pair with VT3 acting as a constant current tail. The unbalanced output from the long-tailed pair is fed to the high gain modulating amplifier consisting of VT7 and VT8 in a composite transistor circuit, whose collector currents are direct coupled to the emitter circuit of the modulating stage of the wide band amplifier, board 25. Localized feedback across VT7 and VT8 is provided by R36 in conjunction with C2 to C6 in order to modify the phase shift characteristics of the system and ensure stability.

A small forward bias current is applied to MR3 and MR4 which brings the diodes to the knee of their characteristic to ensure that minimum distortion is introduced into the modulated signal. These diodes are matched by corresponding diodes MR1 and MR2 on the opposite side of the comparator bridge so that the effect of any variation of diode characteristic with temperature is balanced out.

The CARRIER LEVEL meter is connected to the comparator bridge via two star networks; R12, R21, R23 and R13, R19, R25. This way it registers the difference between the control and the instruction signal, i. e. its reading corresponds to the reference signal and hence to the carrier level.

### 3.6 MODULATION OSCILLATOR

Circuit diagram—Fig. 7.6

Internal modulating signals from 20 Hz to 20 kHz are provided by a Wien bridge oscillator with six switched frequency ranges.

Board 29 carries the Wien bridge capacitors C1 to C6 and C7 to C12, which are selected by SC1F and SC1B. The resistive arms of the bridge

are provided principally by the ganged potentiometers 0RV1A and 0RV1B, the MODULATION FREQUENCY control.

The amplifier and amplitude stabilization components are carried on board (2). VT1 and VT2 are arranged in a high gain composite transistor circuit. This first stage is followed by VT4 acting as a convenient amplifier and by VT5 which is connected as an emitter follower to provide a low impedance output for driving the bridge. Positive feedback is taken from the junction of R16/R17 to the base of VT1 at a frequency that is determined by the Wien bridge.

Negative feedback from the emitter of VT5 is fed via R7 and RV1 to the emitter of VT2. The amount of feedback depends on the impedance of the network R4 and R5 shunted by the diodes MR1 and MR3. The output signal from the oscillator is fed to the peak detector VT3 which charges C4 to a potential proportional to the peak amplitude of the output signal. This potential controls the forward bias applied to MR3 and MR1, thus if the output signal increases, the impedance of the diodes increases, thereby increasing the feedback and maintaining the output level constant. The effective value of C4 is increased by shunting it by 29C13 on the three lower frequency ranges. RV3 is adjusted to balance MR1 and MR3 to prevent 2nd harmonic distortion which would otherwise result.

When the oscillator is not required, oscillation is stopped by shunting the output to earth by SAB. Whenever the switch SAB is on, the modulation oscillator signal is available at the rear terminals TP8, 9.

### 3.7 AMPLITUDE MODULATION DRIVE CIRCUITS

*Circuit diagram—Fig. 7.7*

Amplitude modulating signals either internal from modulation oscillator, or external a. c. coupled from TP3, are selected by the FUNCTION switch, SB, and applied to MODULATION LEVEL control 0RV2. The CARRIER LEVEL control, 0RV3, determines both the amplitude of the modulation signal and the level of d. c. instruction signal, so the modulation depth does not vary with the setting of this control.

### 3.8 A.M./F.M. DRIVE AND MONITOR

*Circuit diagram—Fig. 7.7*

Board (3) carries the a. m./f. m. monitor, also the a. m. and f. m. drivers.

In the a. m. driver, VT1 acts as a current amplifier of the composite instruction signal which is applied to the a. l. c. and envelope feedback circuit.

Monitoring of the modulation level; a. m. depth and f. m. deviation is carried out by M2. The circuitry driving M2 comprises the monitor amplifier, carried on board (4) and the full-wave peak rectifier on board (3). 3VT3 operates as an emitter follower impedance converter to drive the meter, M2, via one of two sensitivity presets, one for a. m. and the other for f. m. (RV2; RV3). 3MR3, 3MR4, 3MR5, in conjunction with the set zero preset 3RV1, provide a zero balancing action free from temperature defect.

A very long time constant is used in the peak detector circuit to ensure accurate readings down to 20 Hz but, to overcome the excessively slow adjustment of modulation monitoring which would otherwise occur, a patented discharge circuit is employed. The system is in essence a trigger circuit comprising 3VT2 and 3VT4, and functions to discharge the metering time constant capacitors C3 and C4 when the MODULATION LEVEL control is turned down.

A direct coupled amplitude modulating and level control path is provided from the front panel terminal TP3, via SB1F, bypassing 3VT1, to the instruction drive circuit of the a. l. c. and envelope feedback unit in the r. f. box.

## 3.9 FREQUENCY MODULATION DRIVE CIRCUITS

*Circuit diagram—Fig. 7.7*

Frequency modulating signals are derived internally from board (2) or externally from terminal TP5 and are monitored as for a. m. The monitored f. m. drive voltage is fed to a three positioned range attenuator.

Direct voltages to provide a calibrated incremental frequency facility are derived from 0RV6, 4VT1 and 4VT8. These voltages are fed through a three position  $\Delta f$  range attenuator.

The outputs from the f. m. and  $\Delta f$  range attenuators are connected in parallel. This composite voltage is fed via a trimming control 0RV7 and the three point tracking arrangement on board (30), SG0 and SG1 to the f. m. driver amplifier on board (3).

Table 3.1

Range	Freq/position	Switch tag	Lead colour
C	100 kHz	SG0b 6	ORANGE/BROWN
C	500 divs	SG1b 6	ORANGE/RED
C	320 kHz	SG0f 7	ORANGE
D	320 kHz	SG0f 5	WHITE/ORANGE
D	500 divs	SG1b 4	WHITE/RED
D	1000 kHz	SG0b 4	WHITE/BROWN
E	1 MHz	SG0b 2	GREEN/BROWN
E	500 divs	SG1b 2	GREEN/RED
E	3.2 MHz	SG0f 3	GREEN/ORANGE
F	3.2 MHz	SG0f 1	BLUE/ORANGE
F	500 divs	SG1b 21	BLUE/RED
F	10 MHz	SG0b 21	BLUE/BROWN
G	10 MHz	SG0b 19	BROWN
G	500 divs	SG1b 19	BLACK/RED
G	32 MHz	SG0f 22	BLACK/ORANGE
H	32 MHz	SG0f 20	GREY/ORANGE
H	500 divs	SG1b 17	GREY/RED
H	72 MHz	SG0b 17	GREY/BROWN

*Leads to the wipers*

SG0f 18	ORANGE
SG1b 13	RED
SG0b 13	BROWN

With the FUNCTION switch in its fully clockwise position, TP5 may be used to provide external  $\Delta f$  via a path which bypasses the tracking network. The direct coupled facilities for electrical control of the carrier amplitude and frequency are connected to amplifiers which have a mean standing potential of half their supply voltage. This potential therefore appears on the appropriate terminals, TP3 and TP5, when the levelling or  $\Delta f$  functions are in use.

The  $\Delta f$ /LEVELLING NEUTRAL terminal, which carries a -6.75 V from a low impedance, is provided at the rear of the instrument for use when this standing potential is an embarrassment.

### 3.10 CRYSTAL CALIBRATOR

*Circuit diagram—Fig. 7.8*

A crystal controlled 1 MHz oscillator is used as the standard to produce a series of harmonics and sub-harmonics which can be compared with an unknown radio frequency. The circuitry is divided between two printed circuit boards. Board ⑥ which is mounted inside the r.f. box, carries all the circuits up to the mixer stage.

The 1 MHz signal follows two paths: firstly to a limiter and then to two cascaded divide by ten circuits that give a train of 100 kHz and 10 kHz



pulses, secondly to a Schmitt trigger and then a pulse shaper for harmonic generation. The output from the pulse shaper meets that from the divider circuits at the input to the mixer and mixes with the r. f. from the wide band amplifier.

1 MHz standard frequency is generated by VT1, which uses a crystal in a modified Colpitts circuit. Trimmer capacitor C34 brings the frequency exactly to 1 MHz. Output is taken via a  $\pi$  filter circuit whose frequency is adjusted to 1 MHz by L1. VT2 is a common base, class C amplifier producing a high level signal. Its output circuit is adjusted to 1 MHz by L2. MR1 and MR2 form a limiter which clips the 1 MHz signal to give a faster rise pulse. When the CRYSTAL CALIBRATOR selector is in the 100 kHz position, the 100 kHz storage counter operates. VT4 and VT5 are held biased non-conducting by R11 and R13. A positive-going pulse edge changes C14 (C15) and C16 and the voltage developed across MR3 holds VT3 off. The negative-going pulse edge turns on VT3 allowing C14 (C15) to discharge, but there is no discharge path for C16 which thereby charges up in a series of steps as successive pulses arrive. The value of C15 is selected to give voltage steps such that when ten have been received the potential across C16 is just sufficient to turn on VT4. A cumulative switching action through the regenerative coupling between VT4 and VT5 occurs, both transistors are rapidly turned on and C16 is discharged. When C16 is discharged, a similar switching action turns both transistors off again. The counter produces an output pulse for every ten input pulses and so, for a 1 MHz input, gives a 100 kHz pulse train output.

The 10 kHz storage counter operates in an exactly similar manner with C22 being charged in steps through C18 (C19) and MR5, and being discharged every tenth step through VT7 and VT8. By feeding a small part of the 100 kHz signal via C21 and R14 forward to the 10 kHz counter, the switching points of the counter are brought into exact synchronism.

A second output from the crystal oscillator, taken via C25, feeds the Schmitt trigger VT9 and VT10, which produces a sharp edged pulse to drive VT11. VT11 operates in the class C mode and conducts for part of the positive-going half of the input waveform. L3 resonates with stray capacitance at 50 MHz and tries to ring at this frequency whenever VT11 conducts. MR7 damps this so that only one negative-going half cycle is produced. The output from VT11 thus consists of a train of 10 ns pulses at a 1 MHz repetition rate and contains a spectrum of 1 MHz harmonics of

approximately equal amplitude throughout the range of the signal generator.

The r. f. carrier from the wideband amplifier is fed via VT13, acting as a buffer stage, to the emitter of VT12. Mixing takes place in VT12 between the r. f. carrier and the 1 MHz, 100 kHz and 10 kHz pulse trains fed to the base. Audio frequency beat note signals are fed from the collector of VT12 via SA2 to the crystal calibrator amplifier, which is carried on board (5)

In the 1 kHz (filter) position of the CRYSTAL CALIBRATOR selector SA2 routes the a. f. signal via a 1 kHz band-stop filter consisting of C9, C10 and L1. VT1, VT2 and VT3 are a conventional a. f. amplifier chain to bring the beat note up to a suitable level to drive headphones on the loud-speaker LS1. The frequency response of the crystal calibrator a. f. system is limited to 1.5 kHz by the filter on boards (7) and (8) and by C6 in the collector circuit of VT2. The CRYSTAL CAL LEVEL control is a potentiometer ORV8 interposed between VT1 and VT2. Its configuration has been chosen to ensure that VT2 is always fed from a high source impedance.

In the OFF position of the CRYSTAL CALIBRATOR selector OC2 is effectively connected between collector and base of VT1 to reduce its gain, by negative feedback, and prevent unwanted audio frequencies being heard.

### 3.11 ATTENUATORS

*Circuit diagram—Fig. 7.9*

Two stepped attenuators are fitted to the instrument, a coarse attenuator giving up to 120 dB loss in 20 dB steps and a fine attenuator giving up to 20 dB in 1 dB steps.

Both attenuators are of similar construction and operation. The pad sections consist of resistive  $\pi$  networks with a characteristic impedance of 50  $\Omega$ . The body is divided into compartments to achieve maximum shielding between pad sections. Pads are brought into circuit by micro-switches housed inside the screened compartments and operated in pairs by leaf springs which are themselves actuated by cams on the control spindles.

To avoid spurious voltages being developed as a result of current flowing in the multiple earth paths, the interconnection between the r. f. box, the attenuators and the front panel, is done with special coaxial cable with a copper tube outer.

### 3.12 R.F. UNIT FILTERS

Circuit diagram—Fig. 7.10

All leads entering and leaving the r. f. unit are filtered by components carried on boards ⑦ and ⑧. These filters are all basically low-pass  $\pi$ -section types, with half sections on board ⑦ and full sections on board ⑧. An additional section is switched into the amplitude modulation drive filter by SG11 to give a lower cut-off frequency at the lower carrier frequency ranges.

### 3.13 POWER SUPPLIES

Circuit diagram—Fig. 7.11

Three stabilizer circuits are employed; the principal stabilizer comprising components mounted on and closely associated with board ①. The a. c. supply input is fed to 0T1, whose primary windings can be arranged in series or in parallel for supply voltages in the ranges 190 - 260 V or 95 - 130 V respectively. MR3 and MR4 constitute a full wave rectifier circuit.

If a d. c. supply is used it is fed to the input to the stabilizer via MR2, which gives protection from incorrect polarity.

0VT1 is the series control transistor and Zener diode MR1 provides the reference voltage for comparison with the base voltage of VT2. Error signals from VT2 are amplified by VT1 and passed to the base of 0VT1.

For the oscillators, crystal calibrator buffer, frequency modulation and  $\Delta f$  drive circuits, an additional -13.5 V stabilizer is provided. The components are carried on board ④. Error signals developed between the base and emitter of VT3 are amplified by VT2 and fed to the base of the series control transistor VT1.

To ensure a low temperature coefficient of voltage on the -13.5 V rail, a compensating bridge, comprising of thermistor TH1, R5; R6, RV2 is fitted.

As previously mentioned, the direct coupled amplifiers in the f. m. and  $\Delta f$  drive circuit require a low impedance -6.75 V neutral line, this requirement is met by the stabilizer using VT4, VT5 and VT6.

## 4.1 INTRODUCTION

This chapter contains information for keeping the equipment in good working order and for checking its overall performance.

Before attempting any maintenance on the signal generator, you are advised to read the preceding Technical Description chapter.

### CAUTION

This instrument uses semiconductor devices which, although having inherent long term reliability and mechanical ruggedness, are susceptible to damage by overloading, reversed polarity and excessive heat or radiation. Avoid hazards such as reversal of batteries, prolonged soldering, strong r.f. fields or other forms of radiation, use of insulation testers or accidentally applied short circuits. Even the leakage current from an unearthed soldering iron could cause trouble. Before shorting or breaking any circuit, refer to the circuit diagrams to establish the effect on bias arrangements of the transistors.

## 4.2 SCREW FASTENERS

Screw threads used on this instrument are of the following sizes: 2BA, 4BA, 6BA, 8BA and 3/8 BSW.

Cruciform headed screws are of the Phillips Pozidriv pattern; to avoid damaging them a Pozidriv screwdriver should be used.

## 4.3 REMOVAL OF CASE

To remove the outer case of the instrument extract the four coin-slotted 2BA screws at the rear and slide the instrument forward out of the case. With the case off, the following boards are accessible, (1), (2), (3), (4), (5), (29); for the location of these boards and other components see Fig. 4.1 and Fig. 4.2.

## 4.4 LOCATION OF SUB ASSEMBLIES AND COMPONENTS

### Removal of the r.f. unit

Extract the eight 2BA screws (four on each side) that secure the screening case of the r.f. unit on the side frames of the main chassis. Disconnect the 18-way plug and socket on the top cross-member of the chassis, and disconnect the two snap-on BNC plugs and sockets on the front bulkhead of the r.f. unit. The unit can then be removed by sliding it out of the back of the instrument, taking care not to foul the interconnecting cable.

With r.f. unit removed, switch wafers SG0 and SG1, the tracking assembly including the potentiometer RV9 and board (30) are accessible. If it is wanted, for test purposes, to operate the instrument with the r.f. unit removed and lying alongside the chassis, this is possible if the 18-way plug and socket are reconnected. The output can then be taken direct from SKT10.

To remove the r.f. unit cover, unscrew the two hexagon socket cap screws at the back of the unit and slide the cover off rearwards. A hexagon wrench to fit these screws is clipped to the top cross-rail of the chassis.

Boards (6), (7) and (8): These boards are located at the rear of the r.f. unit; to reach them unscrew the two 6BA screws that secure the rear cover plate and lift it off.

Boards (25) and (26): These boards are, together with sections 2 to 10 of switch SG, mounted between the oscillators and the output filters. Extract the six 6BA screws holding the upper central cover plate and remove it. Board (26) is then accessible. Remove the lower central cover plate in a similar manner to reveal sections 2 to 10 of switch SG and fuse FS1.

To make measurements or tests on board (25) it must be removed. Do this as follows:

- (a) Turn the range switch to A.
- (b) Slacken the 6BA screws in the switch blade plastic coupling pieces on either side of switch

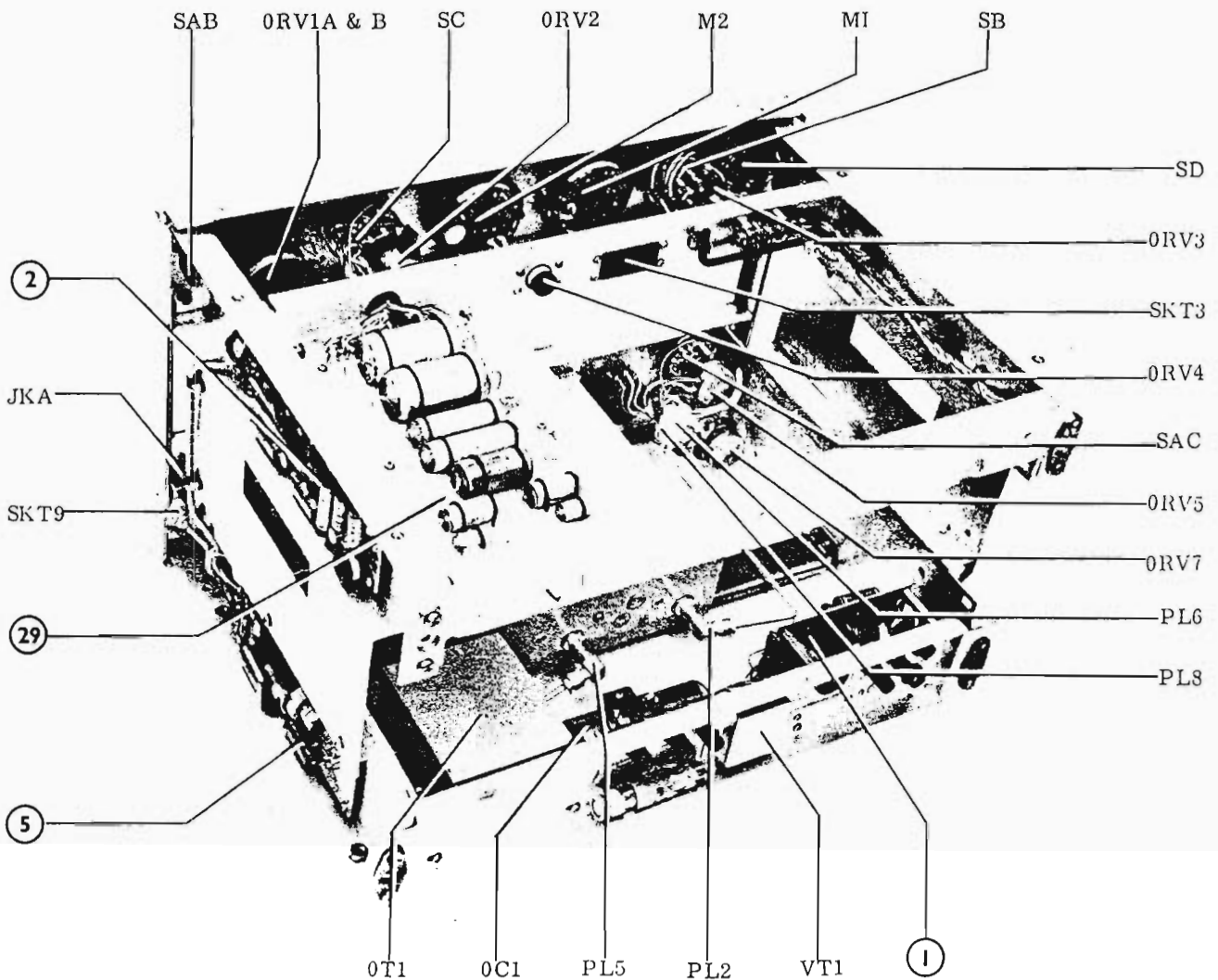

Fig. 4.1 Top view with r.f. unit removed

sections SG9 and SG10 until the coupling pieces slide off the blade.

(c) With the r. f. unit right way up, extract the two 6BA screws that secure the support brackets to the top edge of board (25).

(d) Withdraw the three 6BA screws that secure the brackets on the bottom edge of board (25) to the main drive shaft rear support plate.

The board may now be pulled out through the bottom of the r. f. unit. There is sufficient length of lead to allow the board to be pulled clear of the surrounding metalwork.

Oscillators and output filters; boards (9) to (24): These boards are contained, in pairs, in cast boxes bolted on either side of the r. f. unit; oscillators on the left and output filters on the right. See Figs. 4.3 and 4.4. Access to the component side of each board may be obtained by

removing the cover plate (secured by three 4BA screws) on the outside face of the appropriate box. To get at the print side of a board remove the 6BA screw and two 8BA nuts that hold the board in position and swing it up and clear of the box.

#### Attenuator unit

To remove the attenuator unit:

- (a) Remove the attenuator scale plate (held by two Posidriv screws).
- (b) Slacken the hexagon socket screws securing the attenuator knobs and pull them off.
- (c) Remove the four Posidriv screws securing the attenuator box, two under each dial.
- (d) Disconnect the snap on BNC plugs and sockets at the rear of the attenuator. The nut securing the

50  $\Omega$  output socket on the front panel should be loosened to avoid bending the copper output cable.

- (e) Remove cleat securing counter output cable.
- (f) If the r. f. unit has already been removed from the chassis, the attenuator unit will be freed by extracting the two 4BA screws at each end that secure the bottom cross rail of the chassis.

To open the attenuator unit:

- (a) Slacken the four 6BA screws in slots at the rear of the side of the attenuator unit, and pull off rear cover.
- (b) Remove the six 4BA recessed Posidriv screws from the front of the attenuator unit and lift the coarse and fine attenuators out of the case.
- (c) Access to the individual attenuator components can be obtained by removing the twenty 6BA

screws that secure the rectangular cover plate of each attenuator.

#### 4.5 CIRCUIT VOLTAGES

The voltages given on the circuit diagrams are those which may be expected on a typical TF 2002AS at a mains input of 240 V, using a 20 k $\Omega$ /V meter. All are negative with respect to the positive supply line.

The controls were set to the following positions:

SUPPLY switch	ON
CARRIER switch	ON
RANGE switch board (9) to (16)	the range corresponding to the board
board (25)	G
all other boards	A

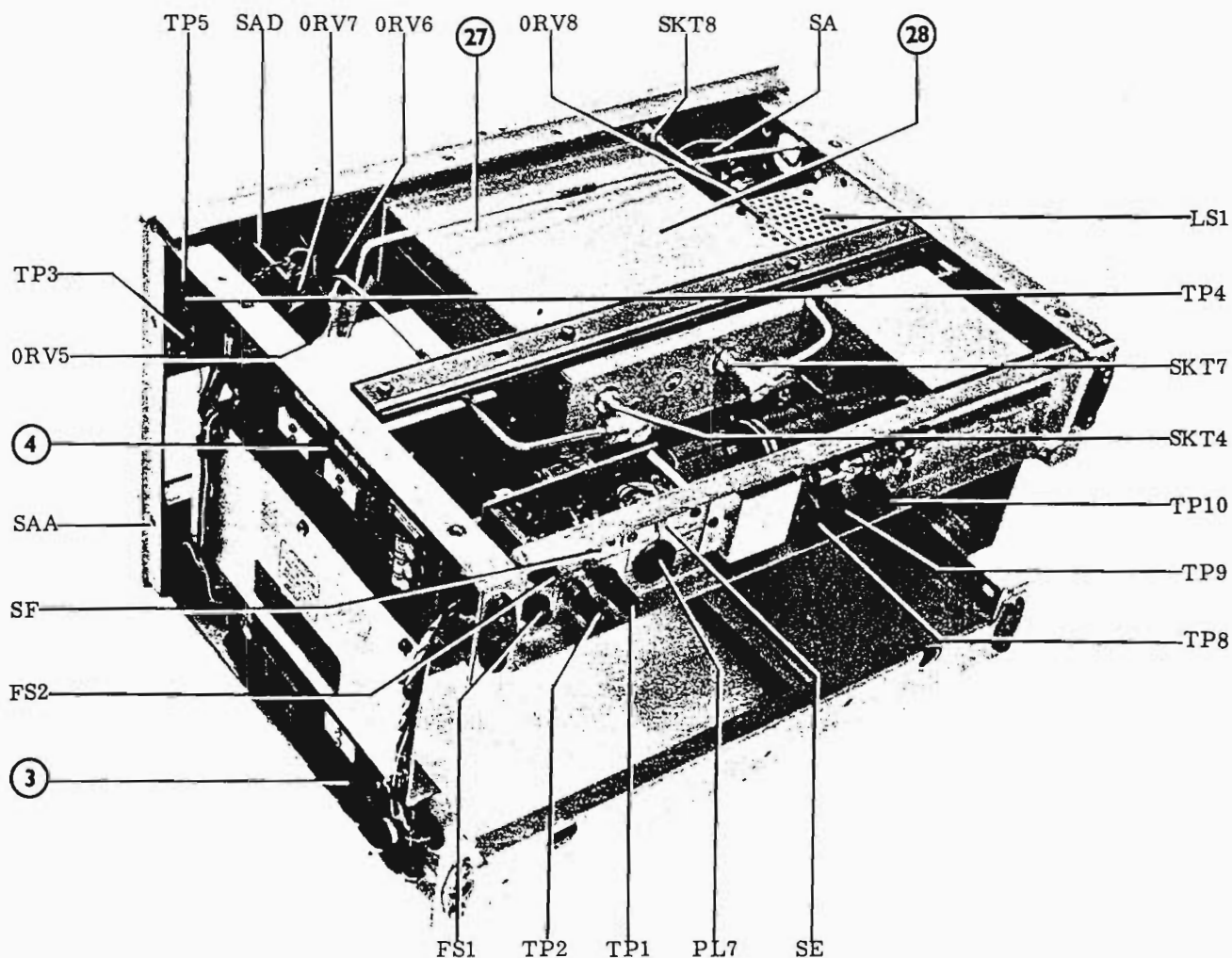

Fig. 4.2 Bottom view with r.f. unit removed

FREQUENCY	500 on logging scale	FUNCTION switch	INT. A. M.
CARRIER LEVEL all boards except (16) board (16)	SET RANGE H for 100% A. M.	INCREMENTAL FREQUENCY control	scale centre zero
ATTENUATORS	90 dB $\mu$ V	$\Delta f$ RANGE	POS 3
CRYSTAL CAL selector	10 kHz	F. M. RANGE	POS 3
CRYSTAL CAL LEVEL control	fully counter-clockwise	SET ZERO control	mid travel
		SET FINE CAL	mid travel
		MODULATION	100 Hz, internal, 80%

For Service Manuals Contact  
 MAURITRON TECHNICAL SERVICES  
 8 Cherry Tree Rd. Chinnor  
 Oxon OX9 4QY  
 Tel:- 01844-351694 Fax:- 01844-352554  
 Email:- enquiries@mauritron.co.uk

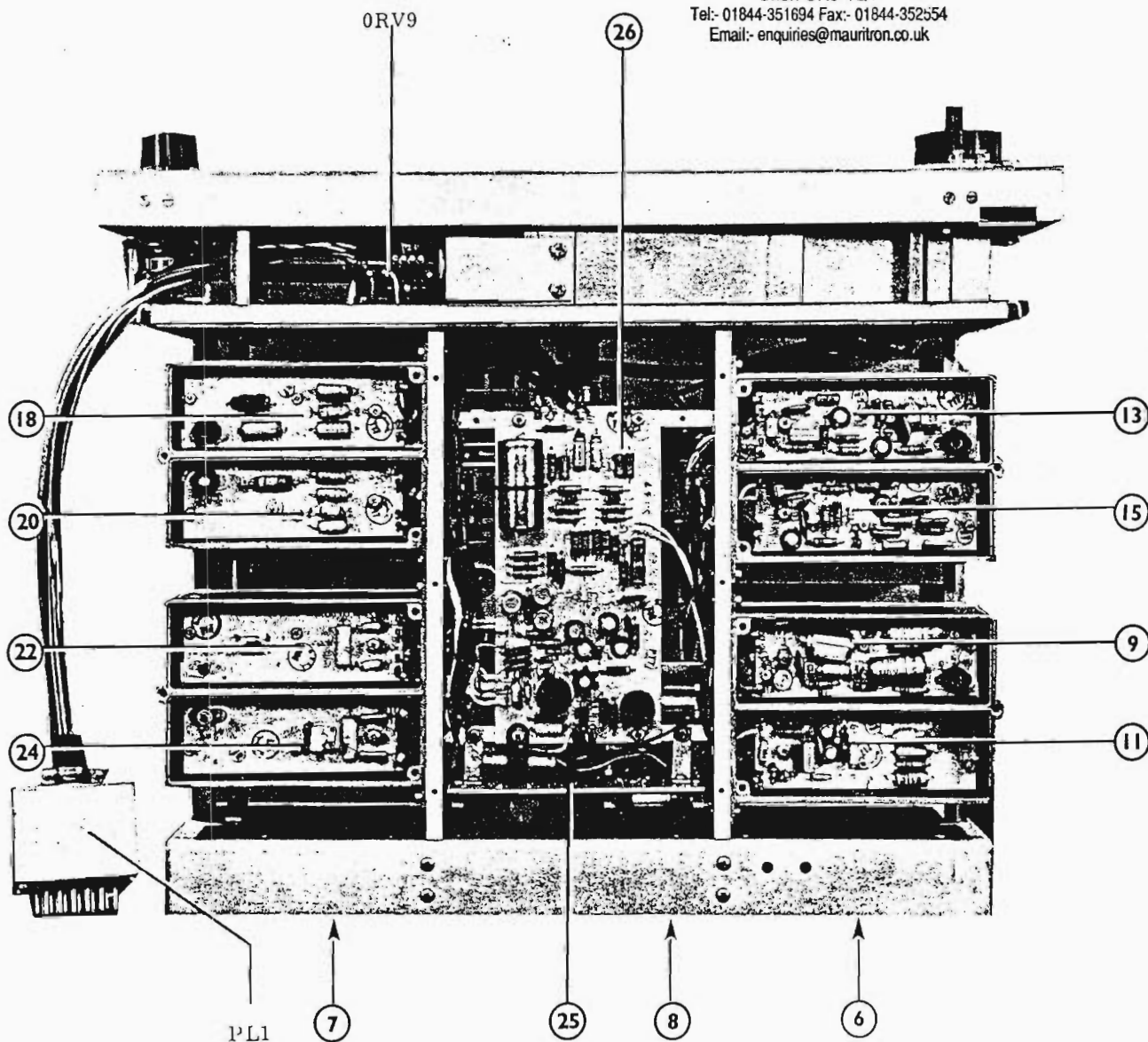

Fig. 4.3 R.F. unit with covers removed—top

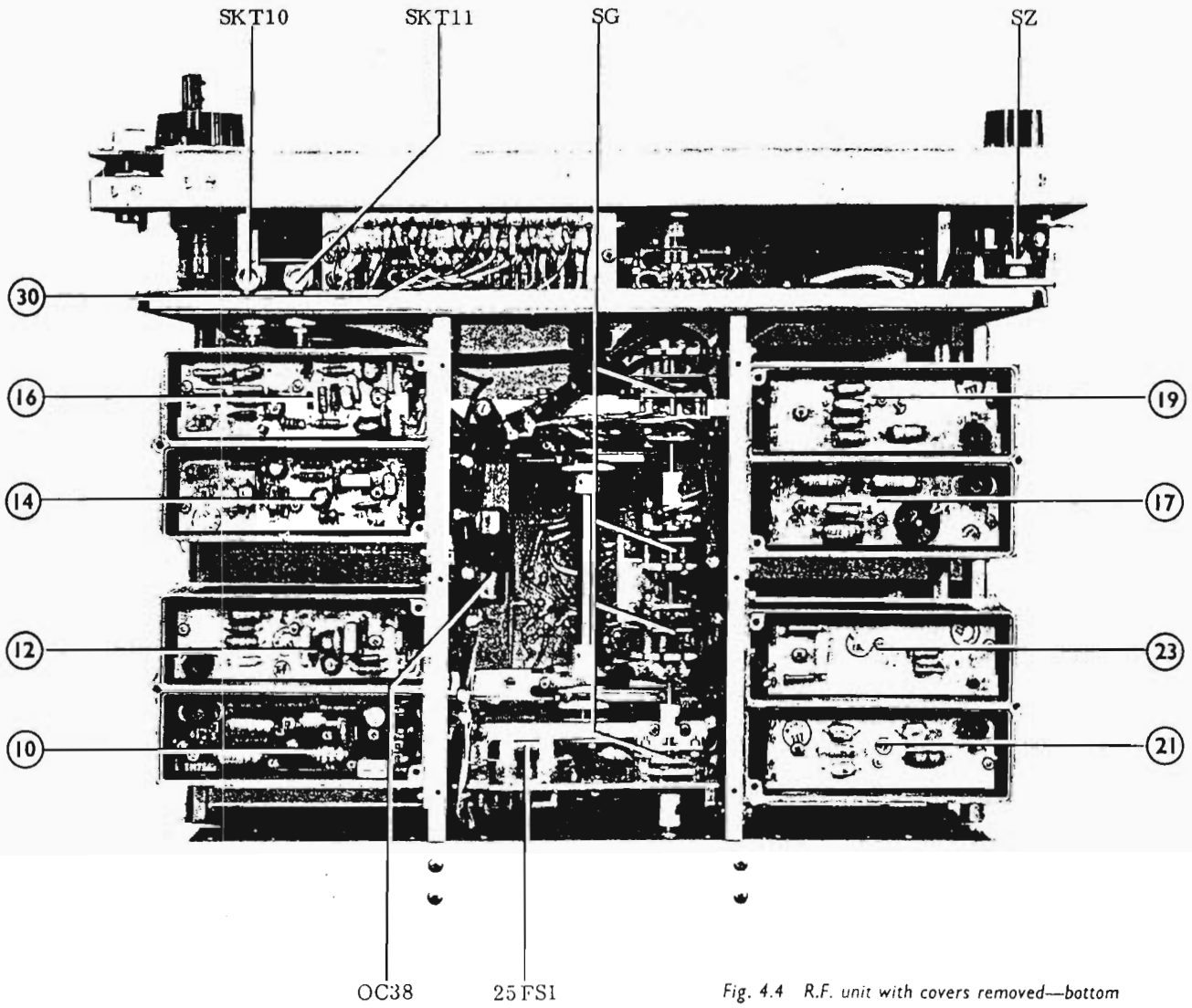

Fig. 4.4 R.F. unit with covers removed—bottom

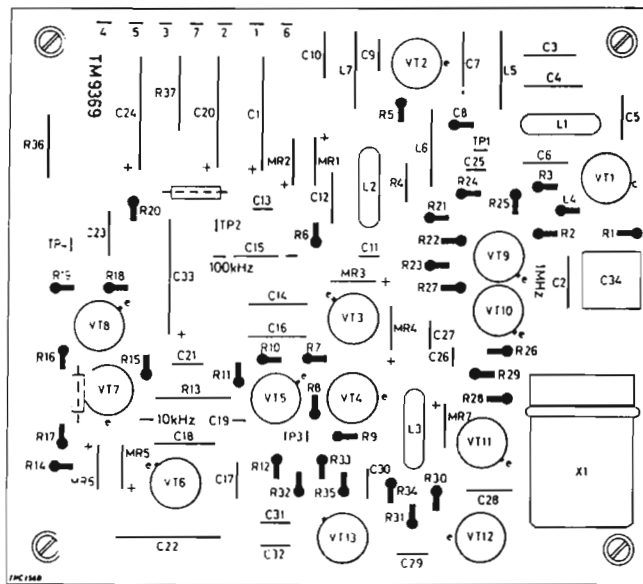

Fig. 4.5 Component layout—crystal calibrator, board 5

### 4.6 WAVEFORMS

The waveforms for boards 25 and 26 were taken on a typical TF 2002AS using a mi Oscilloscope type TF 2200A. For board 6, an oscilloscope with a vertical amplifier having a rise time of 2.2 ns fed by a x10 probe (10 MΩ, 7 pF) was used. Unless otherwise stated the measurement was made between the point indicated and earth.

#### Crystal calibrator—board ⑥

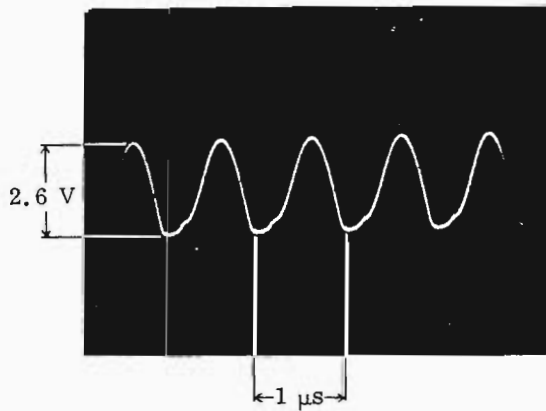

Fig. 4.6 TP1, crystal calibrator selector at 1 MHz

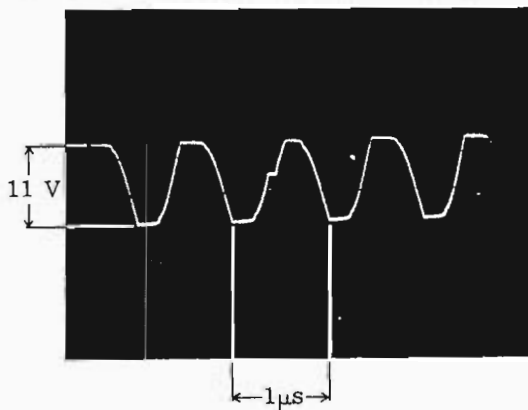

Fig. 4.7 TP2, crystal calibrator selector at 1 MHz

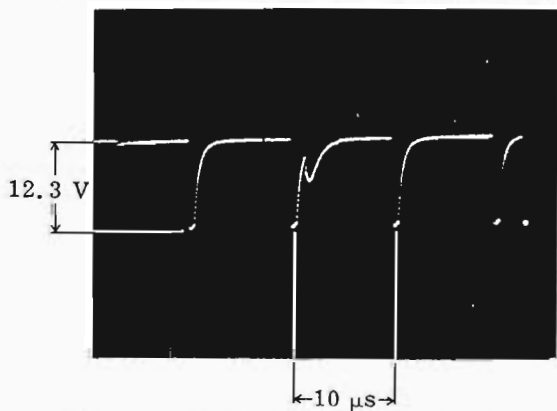

Fig. 4.8 TP3, crystal calibrator selector at 100 kHz

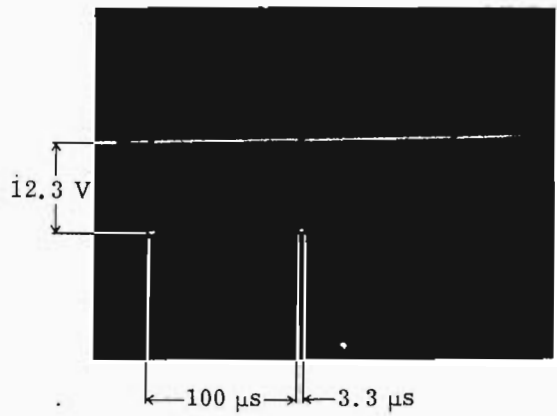

Fig. 4.9 TP4, crystal calibrator selector at 10 kHz

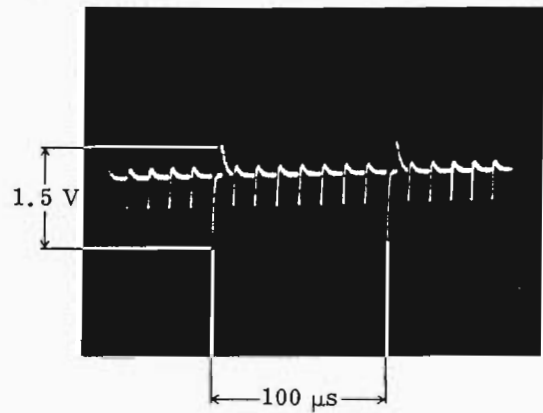

Fig. 4.10 VT12 base, crystal calibrator selector at 10 kHz

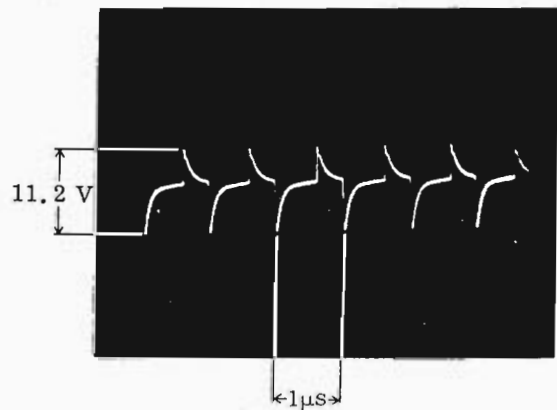

Fig. 4.11 VT11 base, crystal calibrator selector at 1 MHz

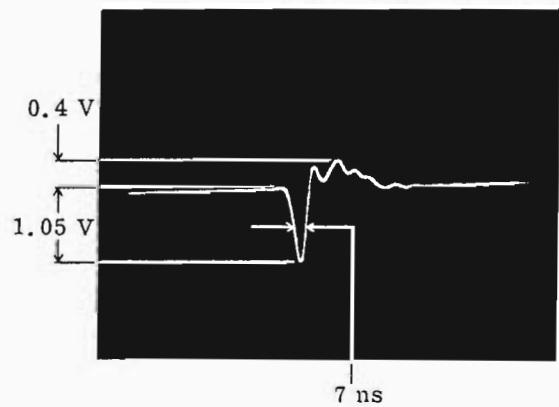

Fig. 4.12 Across L3, crystal calibrator selector at 1 MHz



## Wide band amplifier—board (25)

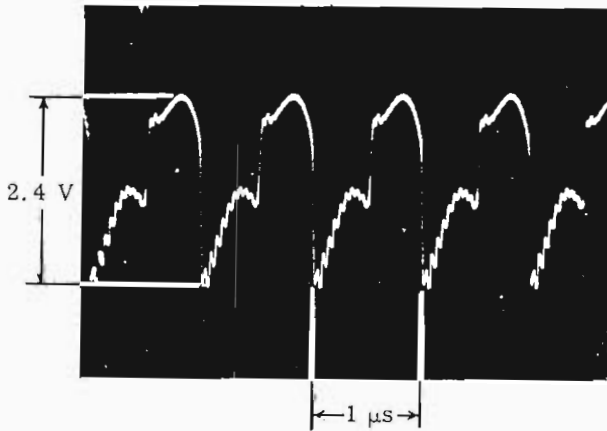

Fig. 4.13 VT7 base, carrier frequency 1 MHz, no modulation

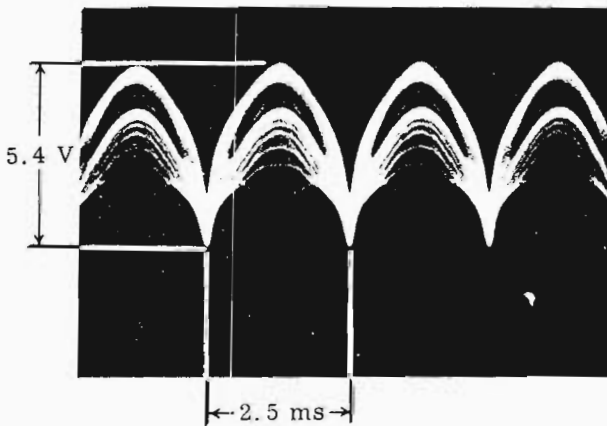

Fig. 4.14 VT7, base carrier frequency 1 MHz, 100% modulation at 400 Hz

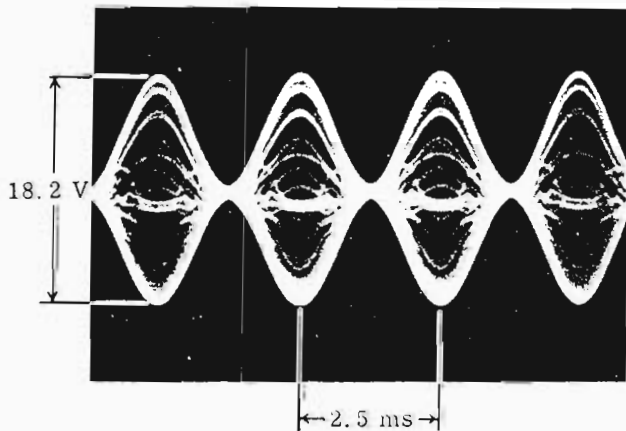

Fig. 4.15 VT7 collector, carrier frequency 1 MHz

## 4.7 CLEANING ROTARY SWITCHES

If it is necessary to clean the contacts of any rotary switches, this should be done with benzine

## A.L.C. and envelope feedback—board (26)

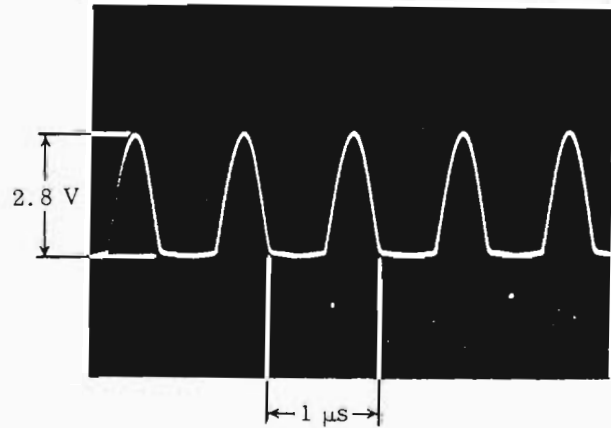

Fig. 4.16 Junction R30 and MR3, carrier frequency 1 MHz, carrier level meter set to 0 dB

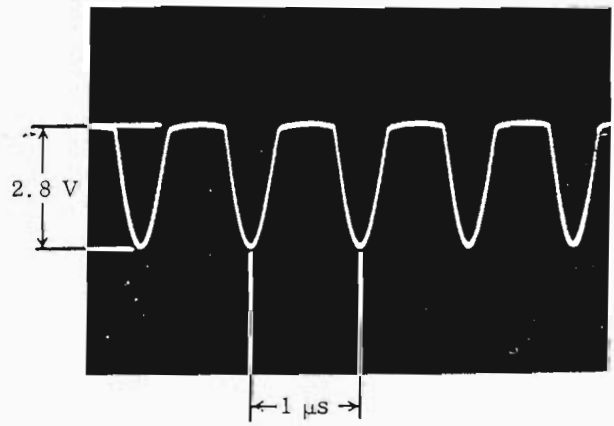

Fig. 4.17 Junction R31 and MR4, carrier frequency 1 MHz, carrier level meter set to 0 dB

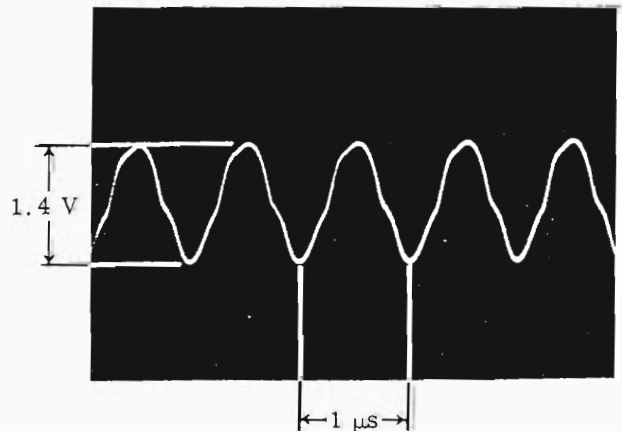

Fig. 4.18 VT3 collector, carrier frequency 1 MHz, carrier level meter set to 0 dB

or white spirit (not carbon tetrachloride) and the contacts should afterwards be wiped with a suitable lubricant such as a 1% solution of petroleum jelly in white spirit. Avoid lubricants containing soap or solid materials.



## 5.1 GENERAL

This chapter is intended to help users to fault find, carry out internal checks, make minor adjustments and realign circuits; use in conjunction with the circuit diagrams at the rear of this manual. Performance limits quoted are for guidance only and should not be taken as guaranteed performance specifications unless they are also quoted in the Data Summary chapter. Details of case removal and access to printed boards are explained in Chapter 4.

### CAUTION

See Sect. 4.1 for precautions in handling semiconductors and Sect. 4.2 for advice on screw fasteners.

In case of any difficulty, please write to or phone the Marconi Instruments Service Division (see address on back cover) or nearest representative, quoting the type and serial number on the data plate at the rear of the instrument. If the instrument is being returned for repair, please indicate clearly the nature of the fault or the work you require to be done.

## 5.2 FAULT LOCATION

In this section five fault finding charts are given which should enable the user to systematically trace a fault to any one particular part of the instrument. The charts should be used in conjunction with the circuit diagrams, static voltages given on the diagrams and test gear listed below.

Test gear required

- a Oscilloscope - general purpose - TF 2200A, TF 2201, TF 2210.
- b Avometer - 20 000  $\Omega/V$  - Model 8.

## 5.3 PRESET CONTROLS

### Power supplies

(a) Connect a voltmeter between tag 3 of board ① and earth, with positive to earth. Apply a nominal a. c. input (230/115 V), and adjust 1RV2 until the meter reads 15 V  $\pm 0.15$  V.

(b) Connect a differential voltmeter such as **mi** TF 2606 between tag 3 of board ① and earth). Apply the mains input via a rotary auto-transformer and swing the voltage from 190 - 260 V. Note the variation of the voltage at tag 3; if this exceeds 20 mV adjust 1RV1 and repeat the test until minimum variation is obtained.

Adjustment of 1RV1 has some interaction on the setting of 1RV2 and, if a substantial alteration has been made, recheck procedure (a) above.

(c) Connect a voltmeter between tag 17 of board ④ and earth, with positive to earth. Adjust 4RV1 until the voltmeter reads 13.5 V  $\pm 100$  mV.

### Amplitude modulation

(a) Turn the MODULATION FREQUENCY control fully clockwise. Adjust 2RV1 so that it is just sufficiently advanced for oscillator to start when the MODULATION selector is turned from the range 2 kHz - 6.3 kHz to the range 6.3 kHz - 20 kHz.

To adjust 2RV3, 2RV1 should be set up, as above.

Connect a distortion factor meter such as **mi** TF 2331 between tag 9 on board ② and earth. Tune the modulation oscillator to about 400 Hz and adjust 2RV3 for minimum distortion. If a large adjustment to 2RV3 has to be made, the setting of 2RV1 should be rechecked.

(b) Connect a frequency meter, such as **mi** counter type TF 2401 or TF 1417 series, to the output of the a. f. oscillator tag 9 of board ②. Set the MODULATION selector to the frequency range 200 Hz - 630 Hz and adjust the MODULATION FREQUENCY control, 0RV1, until the frequency is 200 Hz. Slacken the set screws securing the scale to the spindle of 0RV1 and tune the scale until the cursor is at the 20 mark. Tighten the set screws and advance the MODULATION FREQUENCY control so that the dial reads 63. Adjust 2RV2 so that the frequency is 630 Hz. Recheck the setting of the scale at 200 Hz.

(c) Tune the signal generator to 1 MHz, range E and set the modulation controls to give internal modulation at 400 Hz. Connect an oscilloscope,

Continued on page 47 

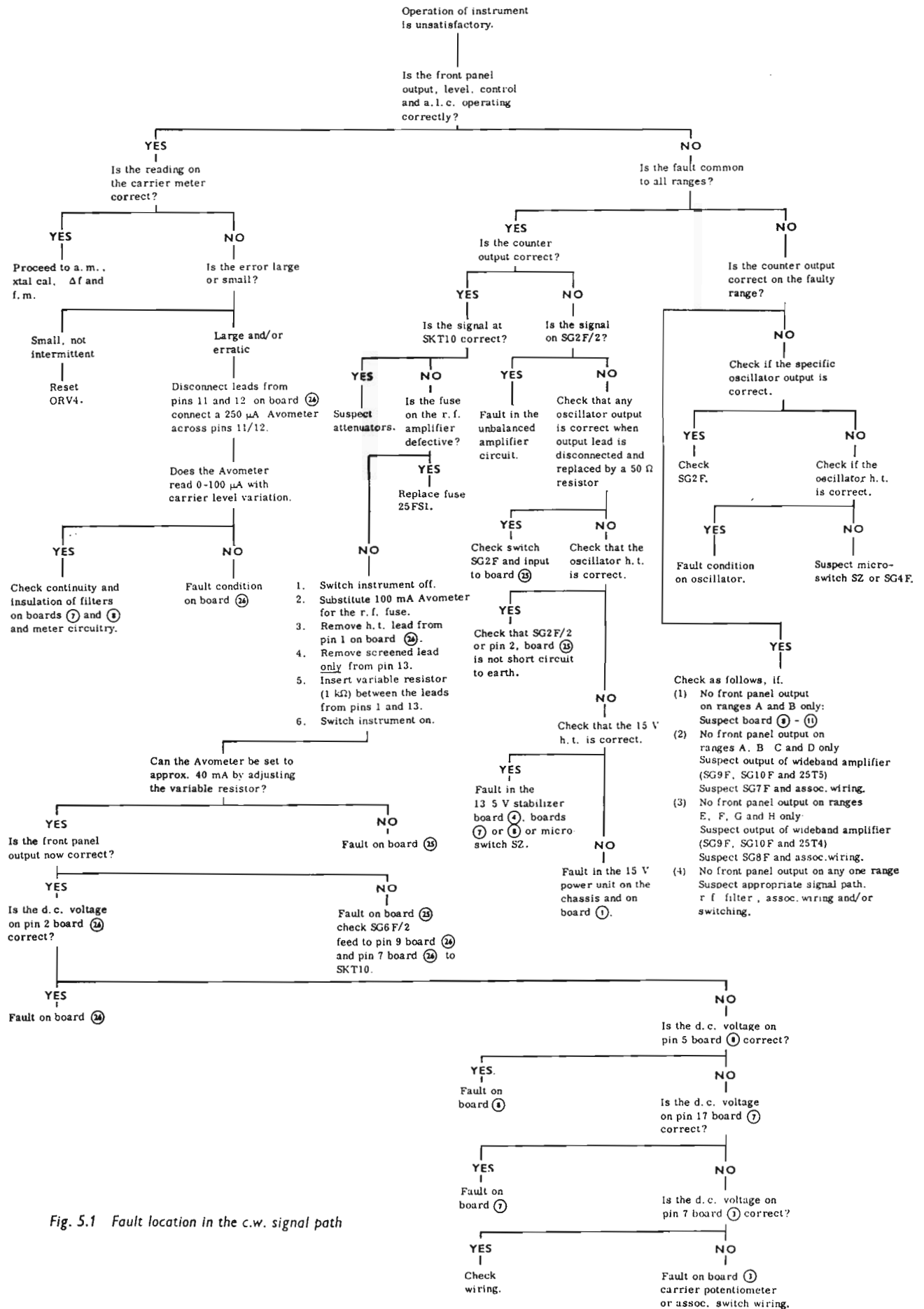

Fig. 5.1 Fault location in the c.w. signal path

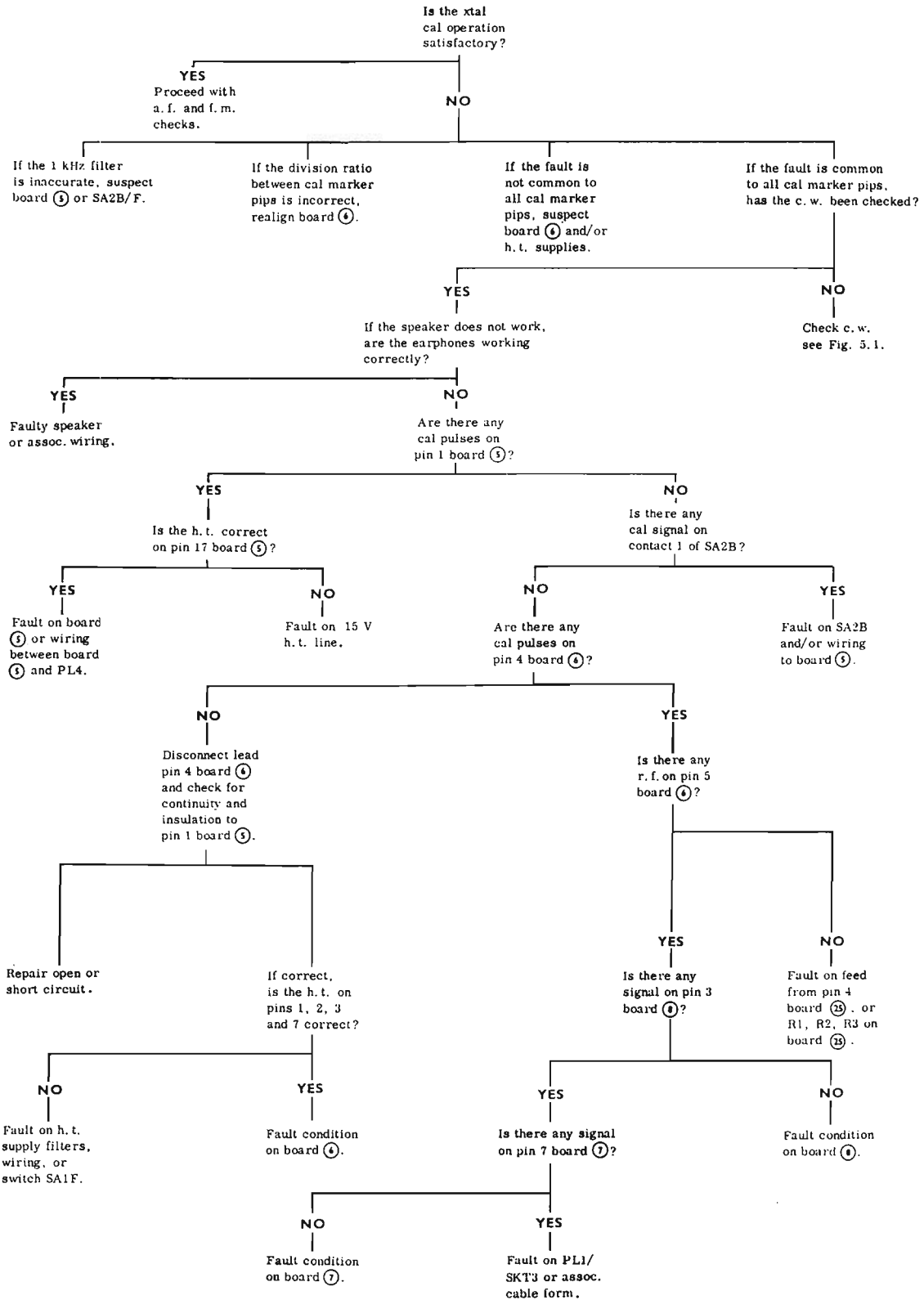

Fig. 5.2 Fault location in the crystal calibrator circuits

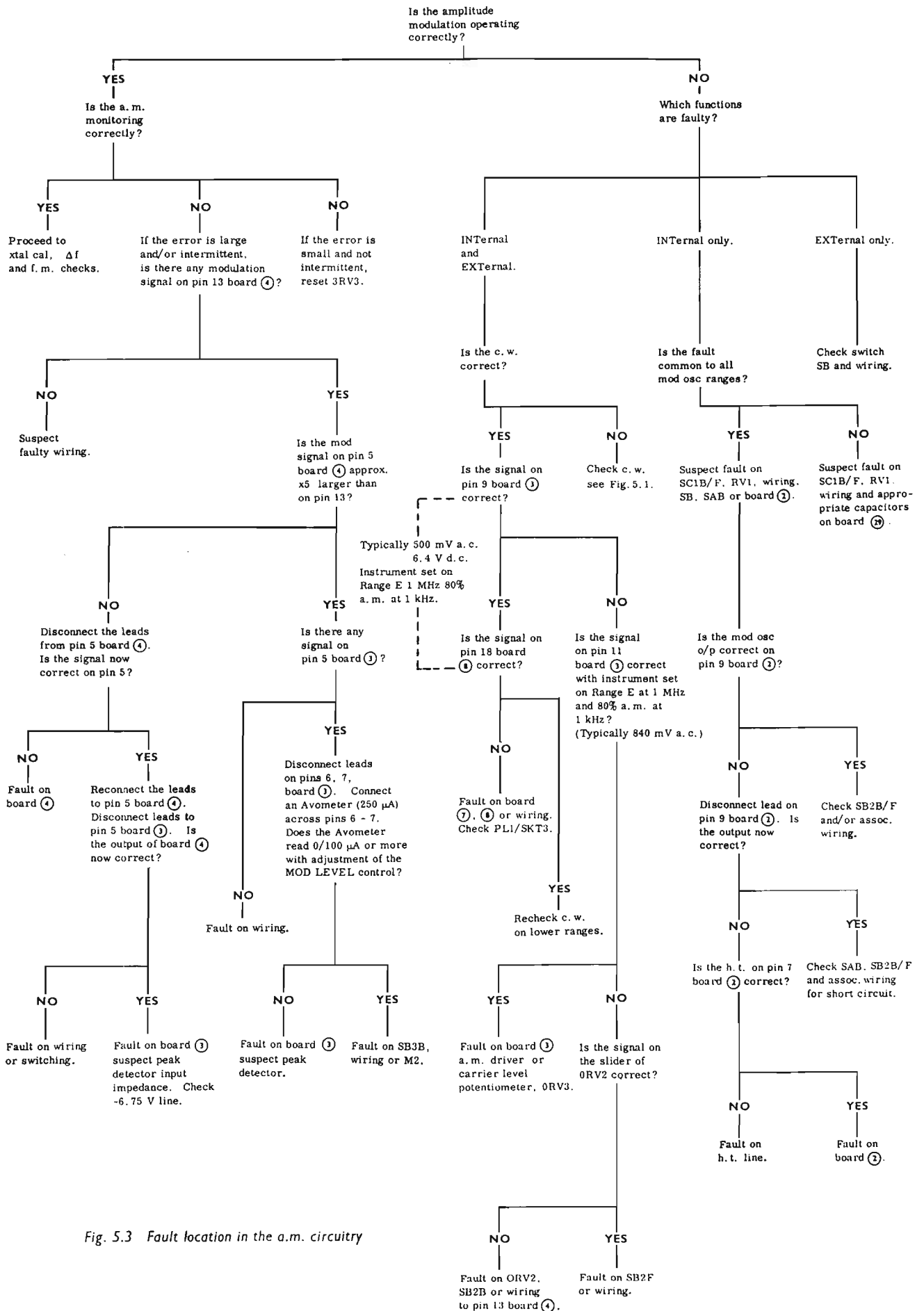

Fig. 5.3 Fault location in the a.m. circuitry

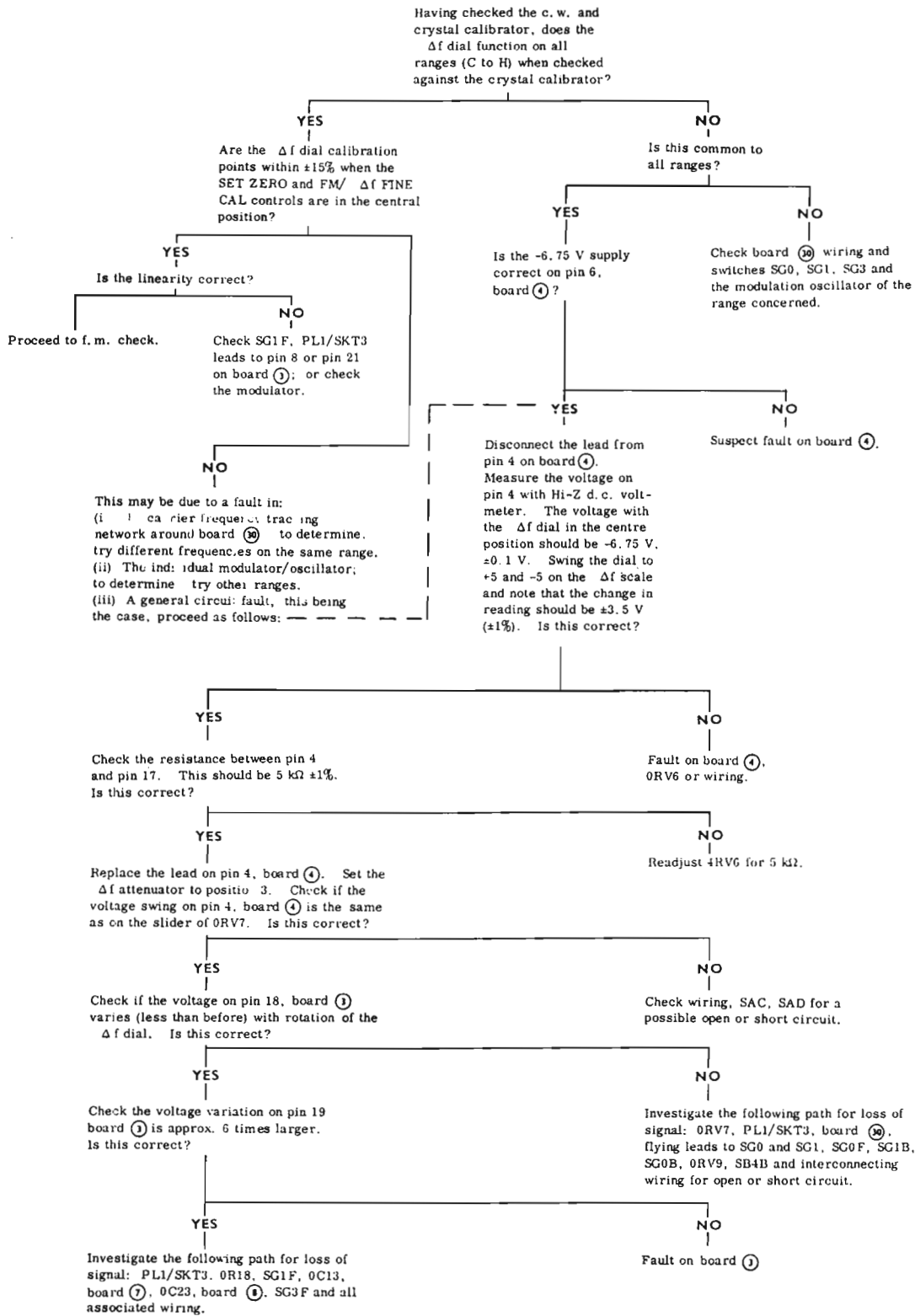
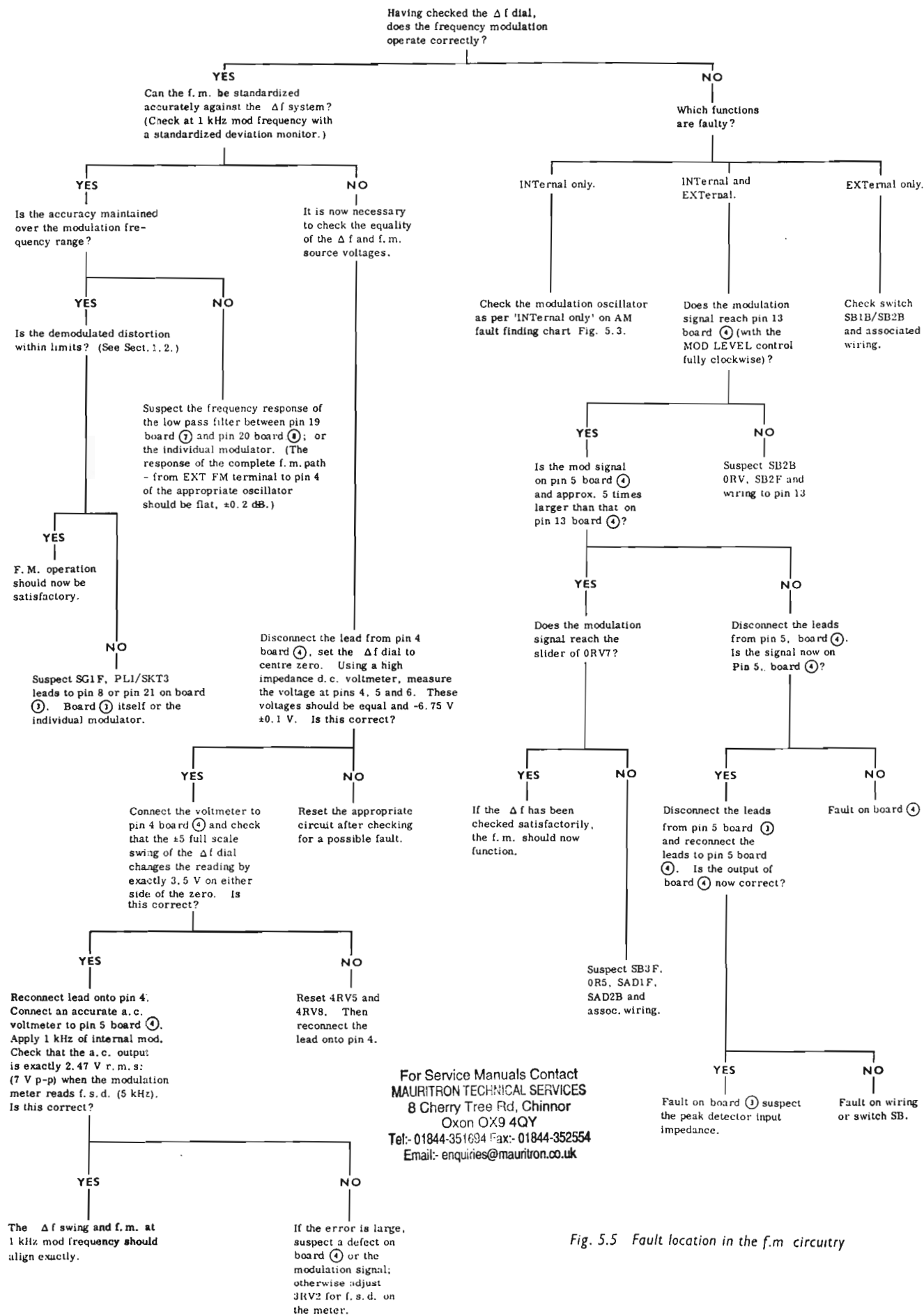

Fig. 5.4 Fault location in the  $\Delta f$  circuitry



For Service Manuals Contact  
**MAURITRON TECHNICAL SERVICES**  
 8 Cherry Tree Rd, Chinnor  
 Oxon OX9 4QY  
 Tel:- 01844-351694 Fax:- 01844-352554  
 Email:- enquiries@mauritron.co.uk

Fig. 5.5 Fault location in the f.m. circuitry



such as **mi** type TF 2200 to the r.f. output socket and advance the MODULATION DEPTH control until the modulation depth, as measured on the oscilloscope, is 50%. Percentage modulation is given by the formula:

$$M (\%) = \frac{D \text{ max} - D \text{ min}}{D \text{ max} + D \text{ min}} \times 100,$$

where D max is the peak-to-peak amplitude and D min the trough-to-trough amplitude of the oscilloscope display. Finally adjust 3RV1 until the MODULATION meter indicates 50%.

NOTE: If it is suspected that the a.l.c. and envelope feedback circuits are out of adjustment, complete the checks given in the preceding section before adjusting 3RV1.

(d) Connect a differential voltmeter such as **mi** TF 2606 between tag 17 of board ④ and earth. Place the whole instrument in a constant temperature enclosure and raise its temperature from 20 to 55 °C. Note the voltage variation at tag 17 over this temperature range: if this exceeds 4 mV, 4RV2 must be adjusted.

Adjust RV2 with the instrument at 55 °C so as to slightly more than compensate for the voltage change that occurred during the temperature rise. Cool the instrument back to 20 °C and again note the voltage change. Repeat the procedure until a variation of 4 mV or less is obtained over the temperature range.

Check that the absolute value of the voltage is still 13.5 V ±100 mV.

Finally using a suitable d.c. voltmeter (Avo 8), adjust 4RV3 until -6.75 V appears on the Δf/LEVELLING NEUTRAL terminal at the rear of the instrument.

Connect an audio oscillator, e.g. a **mi** TF 1101, via a 10 kΩ resistor and a 1 μF capacitor, to the Δf/LEVELLING NEUTRAL terminal at the rear of the TF 2002AS. Set the oscillator to provide a 10 V 1 kHz signal.

Connect a millivoltmeter, such as a **mi** TF 2600, across the Δf/LEVELLING NEUTRAL terminal and earth. See Fig. 5.6. Adjust 4RV4 for a reading of less than 0.5 mV on the millivoltmeter. The impedance cancellation or neutralization has now been adjusted on the -6.75 V line.

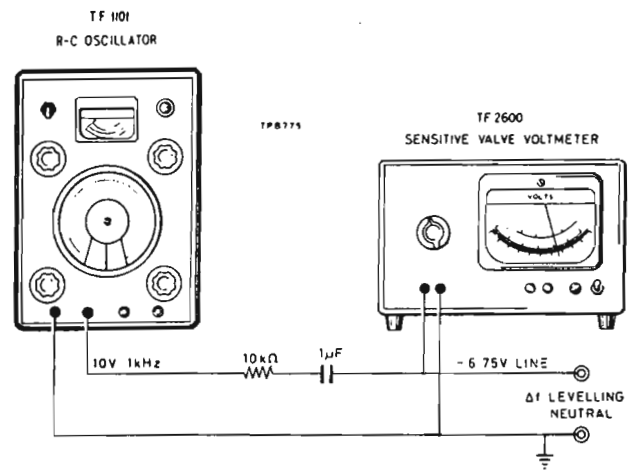

Fig. 5.6 Impedance cancellation of the -6.75 V line

## R.F. oscillators

To check and adjust the frequency accuracy of the r.f. oscillators connect a frequency meter, preferably a counter such as **mi** type TF 2401 or TF 1417 series together with TF 2400 range extension unit, to the COUNTER OUTPUT socket.

Tune the generator to the high frequency end of each range, in turn, and adjust the preset inductor of the appropriate oscillator to bring the oscillator frequency to the scale reading. After adjusting the high frequency end of a range, retune to the low frequency end, and check that the oscillator frequency is within 1% of the scale calibration. To adjust the scale coverage at this end alter the value of C5 on boards ⑨, ⑩, ⑬, ⑭ or C6 on boards ⑪, ⑫, ⑮, ⑯, by a small amount.

## A.L.C. and envelope feedback circuit

For all adjustments in this section, tune the generator to 1 MHz on range E.

(a) To make a preliminary setting up of 26RV1, connect a voltmeter between TP6 and TP7. With the CARRIER LEVEL control fully counter clockwise, adjust 26RV1 for zero reading on the voltmeter.

(b) Connect an oscilloscope, such as **mi** TF 2200, between tag 7 of board ⑳ and earth. The oscilloscope should be set to its most sensitive Y amplifier range (50 mV/cm). With the CARRIER LEVEL control fully counter clockwise adjust 26RV2 to the point, near to zero output, where the r.f. level changes value sharply. This corresponds to an r.f. output level across a 50 Ω load, of about 15 mV.

(c) Connect an accurate r. f. voltmeter across the r. f. output socket terminated with a  $50 \Omega$  load. Advance the CARRIER LEVEL control until the voltmeter reads 1 V. Adjust 0RV4 until the CARRIER LEVEL meter reads exactly 1 V.

(d) Set the generator up to give a signal modulated at 1 kHz by the internal oscillator. View the modulated waveform on an oscilloscope, such as **mi** type TF 2200, connected to pin 7 of board (26) and earth. With the CARRIER LEVEL meter reading 1 V, adjust the MODULATION DEPTH control until the waveform is seen to be modulated to 100%. Reduce the CARRIER LEVEL meter reading to 0.5 V by means of the CARRIER LEVEL control. If the modulation depth has changed, restore it to 100% by adjusting 26RV1. Bring the carrier level to 1 V again and reset the modulation depth to 100%, if it has altered, using the modulation depth control. Repeat this procedure until there is no change of modulation depth between 1 V and 0.5 V carrier levels.

### Frequency modulation

With the instrument switched OFF, disconnect the lead on tags 2 and 4 board (4). Connect an ohmmeter between tag 1 and the lead removed from tag 2.

Rotate INCREMENTAL FREQUENCY dial between +5 and -5 marks, measuring resistance at each end of the dial range, the difference in resistance is the track length R in ohms. (R = approximately  $2.3 \text{ k}\Omega$ .)

$$\frac{7 \text{ volts}}{R} = \text{Current A (approximately 3 mA).}$$

Connect an accurate milliammeter between tags 2 and 6. Switch the instrument ON. Adjust 4RV8 for current A (above) on the milliammeter.

Preset control 4RV7 operates to buck the effective impedance of emitter follower VT7 to near zero, as follows:

Set INT MOD oscillator to 20 Hz, set modulation fully clockwise. In place of the above milliammeter connect a  $2.2 \text{ k}\Omega$  resistor between tags 2 and 17. Measure the a. c. in mV from tag 2 to earth, adjust 4RV7 to minimum. Reconnect the above milliammeter and readjust 4RV8 for current A. Reconnect lead onto tag 2.

Turn INCREMENTAL FREQUENCY control to centre zero. Connect a galvanometer between tags 4 and 6 and adjust 4RV5 for zero on the galvo.

Remove lead from tag 2 and tag 4. With an accurate ohmmeter, (if bridge is used, such as TF 1313, unplug generator), measure the resistance between tags 4 and 17. Adjust 4RV6 for  $5050 \Omega$ .

Adjustment of the  $\Delta f$  Supply is now finished.

Reconnect all leads.

Reconnect the galvanometer between tags 5 and 6. Adjust 4RV9 for zero.

Presets on board (4) now adjusted.

Check all connections are re-made.

Check mechanical zero is set on MODULATION meter.

Switch instrument ON.

Set FUNCTION switch to INT F. M.

Switch modulation oscillator OFF.

Adjust 3RV1 to zero MODULATION meter.

Set MODULATION OSCILLATOR to approximately 1 kHz. Connect an accurate audio voltmeter between tag 5, board (4), and earth. Adjust SET MOD control until the voltmeter reads 2.47 V r. m. s.

Adjust 3RV2 for a deflection of 5 kHz on MODULATION meter.

F. M. RANGE switch on position 3.

Carrier range switch on either C, D, E or F; (select suitable range) and adjust the MOD LEVEL control until a conveniently large voltage, (e. g. 0.4 V), appears on tag 18, board (3) using an audio voltmeter. Note reading on voltmeter.

Turn INCREMENTAL FREQ dial and SET ZERO control (0RV5 and 6) to their central positions. Connect a galvanometer between tags 19 and 12, board (3). Adjust 3RV4 to zero the galvo. Connect an Avo across 3RV22 and adjust 3RV6 until 1 V is measured.

Connect the voltmeter to tag 19, and adjust 3RV5 for x6, the reading obtained in previous check. (i. e  $6 \times 0.4 \text{ V} = 2.4 \text{ V}$ ).

Presets on board (3) now adjusted.

## Crystal calibrator

### (a) 1 MHz OSCILLATOR AND AMPLIFIER.

Connect an oscilloscope, such as **mi** type TF 2201, via a 10:1 probe to TP1. Set the CRYSTAL CALIBRATOR selector to 1 MHz and adjust L1 for maximum waveform clipping. Transfer the oscilloscope to TP2 and adjust L2 for maximum clipping. Connect a counter type frequency meter, such as **mi** type TF 2401 or TF 1417 series to TP2 and adjust trimmer C34 until the frequency indicated by the counter is exactly 1 MHz  $\pm$ 1 Hz.

### (b) STORAGE COUNTERS

It is possible to check the operation of the 100 kHz and 10 kHz storage counters without the aid of other test apparatus.

Tune the signal generator to 100 kHz and turn the CRYSTAL CALIBRATOR selector to 100 kHz. Using either headphones or the internal loudspeaker, slightly adjust the FREQUENCY control until a marker beat frequency is heard and brought to zero.

If this occurs between 99 and 101 kHz, the counter is working correctly. If the marker point is substantially away from 100 kHz, the counter is

dividing by 9 or 11 and a new value must be selected for C15 so that the counter divides by 10.

A similar procedure is to be followed for the 10 kHz counter with the CRYSTAL CALIBRATOR selector set to 10 kHz and the signal generator tuned to 10 kHz. C19 must have a new value selected if the division ratio is not 10.

(c) Turn the CRYSTAL CALIBRATOR selector to 1 kHz (filter).

Connect an accurate (1%) a. f. oscillator, such as **mi** type TF 1101 or TF 2000 via a 47 k $\Omega$  series resistor between tags 5 and 11 of board (5) and connect a valve voltmeter between tags 8 and 11 of board (5). With the a. f. oscillator tuned to 1 kHz, adjust 5L1 and 5RV1 for minimum indication on the valve voltmeter.

To avoid overload do not allow the valve voltmeter reading to exceed 2 V with the CRYSTAL CALIBRATOR LEVEL control, 0RV8, at maximum.

The circuit can be set up almost as well using aural detection of the maximum rejection point.

# Replaceable parts

## Introduction

Each of the printed boards and other sub-assemblies in this instrument has been allocated a unit identification number in the sequence (1) to (31), which wherever practicable is marked upon it. The complete circuit reference for a component carries its unit number as a prefix, e.g. 6R15. Components that do not form part of any sub-assembly carry the prefix 0, e.g. 0R6, except those classes of component about which no confusion is possible.

For convenience in the text and on the circuit diagrams, the circuit reference is abbreviated by dropping the prefix, except where there is risk of ambiguity. When ordering spare parts or in any other correspondence, be sure to quote the complete circuit reference.

This section lists the components of each unit in alpha-numerical order of the complete circuit reference. The following abbreviations are used:-

C	: capacitor
Cer	: ceramic
Elec	: electrolytic
FS	: fuse
JK	: jack
L	: inductor
LS	: loudspeaker
M	: meter
Met	: metal
Min	: minimum
MR	: semiconductor diode
Ox	: oxide
PL	: plug
R	: resistor
RV	: variable resistor
S	: switch
SKT	: socket
T	: transformer
TE	: total excursion
TH	: thermistor
Var	: variable
VT	: transistor
WW	: wirewound
X	: crystal
∅	: feed through
†	: value selected during test; nominal value shown
W	: resistor rating at 70°C
W*	: resistor rating at 55°C
W**	: resistor rating at 40°C
W***	: resistor rating at 20°C

## Ordering

When ordering replacement parts, address the order to our Service Division (for address see rear cover) or nearest Agent. Specify the following information for each part required.

- (1) Type and serial number of instrument.
- (2) Complete circuit reference.
- (3) Description.
- (4) M.I. code number.

If a part is not listed, state its function, location and description when ordering.

## Main chassis

Circuit reference	Description	M.I. code
C1	Elec 1000µF +50-20% 100V	26427-121
C2	Cer 0.1µF +50-25% 30V	26383-031
C3	Elec 1µF +100-20% 50V	26414-106
C4	Cer ∅ 0.0047µF +∞-0 350V	26372-615
C5	Cer ∅ 0.0047µF +∞-0 350V	26372-615
C6	Cer ∅ 0.0047µF +∞-0 350V	26372-615
C7	Cer ∅ 0.0047µF +∞-0 350V	26372-615
C8	Cer ∅ 0.0047µF +∞-0 350V	26372-615
C9	Cer ∅ 0.0047µF +∞-0 350V	26372-615
C10	Cer ∅ 0.0047µF +∞-0 350V	26372-615
C11	Cer ∅ 0.0047µF +∞-0 350V	26372-615
C12	Cer ∅ 500pF 25% 500V	26373-609
C13	Cer ∅ 500pF 25% 500V	26373-609
C14	Cer ∅ 0.0047µF +∞-0 350V	26372-615
C15	Cer ∅ 0.0047µF +∞-0 350V	26372-615
C16	Cer ∅ 0.0047µF +∞-0 350V	26372-615
C17	Cer ∅ 0.0047µF +∞-0 350V	26372-615
C18	Cer ∅ 0.0047µF +∞-0 350V	26372-615
C19	Cer ∅ 0.0047µF +∞-0 350V	26372-615
C20	Cer ∅ 0.0047µF +∞-0 350V	26372-615
C21	Cer ∅ 0.0047µF +∞-0 350V	26372-615
C22	Cer ∅ 500pF 25% 500V	26373-609

When ordering, prefix circuit reference with 0

Circuit reference	Description	M.I. code	Circuit reference	Description	M.I. code
			PL6	Elbow BNC 'snap-on' part of	43125-058
C23	Cer $\emptyset$ 500pF 25% 500V	26373-609	PL7	3 pin mains	23423-151
C24	Cer $\emptyset$ 0.0047 $\mu$ F + $\infty$ -0 350V	26372-615	PL8	Elbow BNC 'snap-on' part of	43126-035
C25	Cer $\emptyset$ 0.0047 $\mu$ F + $\infty$ -0 350V	26372-615			
C26	Cer $\emptyset$ 0.0047 $\mu$ F + $\infty$ -0 350V	26372-615			
C27	Cer $\emptyset$ 0.0047 $\mu$ F + $\infty$ -0 350V	26372-615			
			R1	Carbon 10k $\Omega$ 10% $\frac{1}{2}$ W	24342-110
			R2	Carbon 10k $\Omega$ 10% $\frac{1}{2}$ W	24342-110
C34	Cer $\emptyset$ 0.0047 $\mu$ F + $\infty$ -0 350V	26372-615	R3	Carbon 1M $\Omega$ 10% $\frac{1}{2}$ W	24342-166
C35	Cer 0.01 $\mu$ F +80-20% 100V	26383-055	R4	Carbon 100k $\Omega$ 10% $\frac{1}{2}$ W	24342-135
C36 †	Cer 33pF $\pm$ 5% 750V	26324-822	R5	Carbon 4.950 $\Omega$ 1% $\frac{1}{4}$ W	24134-497
C37	Elec 100 $\mu$ F +100-20% 25V	26417-158	R6	Carbon 6.111k $\Omega$ 1% $\frac{1}{4}$ W	24138-724
C38	Elec 500 $\mu$ F +50-20% 25V	26417-175	R7	Carbon 9.625k $\Omega$ 1% $\frac{1}{4}$ W	24138-734
			R8	Carbon 7.115k $\Omega$ 1% $\frac{1}{4}$ W	24138-728
FS1	160mA, time-lag	23411-054	R9	Carbon 24.75k $\Omega$ 1% $\frac{1}{4}$ W	24138-785
FS2	500mA, time-lag	23411-056	R10	Carbon 9.625k $\Omega$ 1% $\frac{1}{4}$ W	24138-734
			R11	Carbon 6.111k $\Omega$ 1% $\frac{1}{4}$ W	24138-724
JKA	Crystal cal output	23421-662	R12	Carbon 6.111k $\Omega$ 1% $\frac{1}{4}$ W	24138-724
			R13	Carbon 9.625k $\Omega$ 1% $\frac{1}{4}$ W	24138-734
L1	Ferrite bead	44223-801	R14	Carbon 7.115k $\Omega$ 1% $\frac{1}{4}$ W	24138-728
L2	Ferrite bead	44223-801	R15	Carbon 24.75k $\Omega$ 1% $\frac{1}{4}$ W	24138-785
L3	Ferrite bead	44223-801	R16	Carbon 9.625k $\Omega$ 1% $\frac{1}{4}$ W	24138-734
L4	Ferrite bead	44223-801	R17	Carbon 6.111k $\Omega$ 1% $\frac{1}{4}$ W	24138-724
L5	Ferrite bead	44223-801	R18	Met ox 1.15k $\Omega$ 0.5% $\frac{1}{2}$ W	24755-481
L6	Five ferrite beads	23635-833	R19	Met ox 27k $\Omega$ 7% TE 3/8W	24552-120
L7	Five ferrite beads	23635-833	R20	Carb 220 $\Omega$ 10% $\frac{1}{2}$ W	24342-058
L8	Five ferrite beads	23635-833	R21	Carb 10k $\Omega$ 10% $\frac{1}{2}$ W	24342-110
			R22	Carb 820k $\Omega$ 10% $\frac{1}{2}$ W	24342-161
LS1	70 $\Omega$	23646-103			
			RV1a	WW 16k $\Omega$ 2% 3W**	25874-578
M1	100 $\mu$ A	44572-216	RV1b	WW 15k $\Omega$ 2% 3W**	25874-578
M2	100 $\mu$ A	44572-215	RV2	2.5k $\Omega$ , part of switch assy. SC	
MR1	1S44	28357-548	RV3	1k $\Omega$ , part of switch assy. SB	
			RV4	Carbon 4.7k $\Omega$ 20% $\frac{1}{4}$ W*	25611-122
PL1	18-way	23435-243	RV5	Part of switch assy. SAC	
PL2	Elbow BNC 'snap-on' part of	43125-058	RV6	WW 2.5k $\Omega$ 10% 3W part of	44371-247
PL3	Elbow GP 50 $\Omega$	23444-053	RV7	2.2k $\Omega$ part of switch assy. SAD	
PL4	Elbow GP 50 $\Omega$	23444-053	RV8	100k $\Omega$ , part of switch assy. SA	
PL5	Elbow BNC 'snap-on' part of	43126-034	RV9	WW 100k $\Omega$ 5% $\frac{1}{2}$ W**	44372-015

For symbols and abbreviations see introduction to this chapter

Replaceable parts

When ordering, prefix circuit reference with 0

Circuit reference	Description	M.I. code	Circuit reference	Description	M.I. code
			SAA	Carrier ON-OFF switch	23462-258
			SAB	Modulation osc. ON-OFF switch	23462-252
SA	Crystal Cal switch assembly includes ORV8	44324-219	SAC	Δf Range switch assy. includes ORV5	44322-131
SB	Function switch assembly includes ORV3	44325-206	SAD	FM Range switch assy. includes ORV7	44322-419
SC	Modulation switch assembly includes ORV2	44324-716	SAE	Microswitch	23483-131
SD	Supply	44321-406	SAF	Microswitch	23483-131
SE	Supply voltage range	23467-119	SAG	Microswitch	23483-131
SF	Mains/battery	23467-116	SAH	Microswitch	23483-131
SG	Range switch		SKT3	18-way	23435-293
SG0	Wafer	44332-419	SKT4	Panel jack BNC 'snap-on' 50Ω	23445-214
SG1	Wafer	44332-419	SKT5	GP 50Ω	23444-193
SG2	Wafer	44332-403	SKT6	GP 50Ω	23444-193
SG3	Wafer	44332-402	SKT7	Panel jack BNC 'snap-on' 50Ω	23445-214
SG4	Wafer	44332-401	SKT8	Bulkhead jack BNC 50Ω	part of 43126-034
SG5	Wafer	44332-404	SKT9	Bulkhead jack BNC 50Ω	part of 43126-035
SG6	Wafer	44332-403	SKT10	Panel jack BNC 'snap-on' 50Ω	23445-273
SG7	Wafer	44332-405	SKT11	Panel jack BNC 'snap-on' 50Ω	23445-273
SG8	Wafer	44332-406			
SG9	Wafer	44332-407	TP1	Terminal miniature	23235-176
SG10	Wafer	44332-408	TP2	Terminal miniature	23235-176
SG11	Wafer	44332-409	TP3	Terminal miniature	23235-176
SH	Microswitch	23483-131	TP4	Terminal miniature	23235-177
SJ	Microswitch	23483-131	TP5	Terminal miniature	23235-176
SK	Microswitch	23483-131	TP8	Terminal miniature	23235-177
SL	Microswitch	23483-131	TP9	Terminal miniature	23235-176
SM	Microswitch	23483-131	TP10	Terminal miniature	23235-176
SN	Microswitch	23483-131			
SP	Microswitch	23483-131	T1	Mains	43456-006
SQ	Microswitch	23483-131	VT1	2N1534	28425-835
SR	Microswitch	23483-131			
SS	Microswitch	23483-131	Knob Supply		41142-209
ST	Microswitch	23483-131	Knob Carrier level control		41141-503
SU	Microswitch	23483-131	Knob Modulation osc. range selector		41142-212
SV	Microswitch	23483-131	Knob Modulation level control		41141-503
SW	Microswitch	23483-131			
SX	Microswitch	23483-131			
SY	Microswitch	23483-131			
SZ	Microswitch	23483-131			

For symbols and abbreviations see introduction to this chapter

When ordering, prefix circuit reference with 0

Circuit reference	Description	M.I. code
Knob, Modulation frequency Boss and Dial for above		41141-308 41174-017
Knob, Frequency Boss and Dial for above		41146-015 41174-011
Knob Set scale control		31141-111
Knob Carrier range control		41145-206
Knob Set zero control		41141-405
Knob $\Delta f$ Range control		41145-231
Knob FM/ $\Delta f$ Trim FS control		41141-405
Knob FM Range control		41145-231
Knob, Incremental frequency Potentiometer, Boss and Dial for above		41141-307 44371-247
Knob, Coarse attenuator Boss and Dial for above		41144-301 41174-010
Knob, Fine attenuator Boss and Dial for above		41144-301 41174-013
Knob Crystal cal selector		41145-220
Knob Crystal cal level		41141-503

Fuse holder for FS1		23416-191
Fuse holder for FS2		23416-191

Unit ① —Power Unit, TM 7466

When ordering, prefix circuit reference with 1

C1	Elec 100 $\mu$ F +100-20% 50V	26417-160
C2	Elec 100 $\mu$ F +100-20% 25V	26417-158
C3	Elec 100 $\mu$ F +100-20% 25V	26417-158
MR1	ZB7.5 Zener	28371-606
MR2	1N540	28357-048
MR3	1N540	28357-048
MR4	1N540	28357-048
R1	Carbon 2.2k $\Omega$ 10% $\frac{1}{2}$ W	24342-088
R2	WW 3.3 $\Omega$ 10% $1\frac{1}{2}$ W***	25133-008
R3	Carbon 220 $\Omega$ 10% $\frac{1}{2}$ W	24342-058
R4	Carbon 6.8k $\Omega$ 10% $\frac{1}{2}$ W	24342-106

When ordering, prefix circuit reference with 1

Circuit reference	Description	M.I. code
R5	Carbon 100 $\Omega$ 10% $\frac{1}{2}$ W	24342-050
R6	Met ox 3.9k $\Omega$ 7% $\frac{3}{8}$ W*	24552-096
R7	Met ox 2.7k $\Omega$ 7% $\frac{3}{8}$ W*	24552-092
R8	Met ox 75k $\Omega$ 7% $\frac{3}{8}$ W*	24552-132
R9	Met ox 2.7k $\Omega$ 7% $\frac{3}{8}$ W*	24552-092
R10	Met ox 2.7k $\Omega$ 7% $\frac{3}{8}$ W*	24552-092
RV1	Carbon 220k $\Omega$ 20% $\frac{1}{4}$ W	25611-229
RV2	Carbon 470 $\Omega$ 20% $\frac{1}{4}$ W	25611-246
VT1	ACY17	28426-497
VT2	2N3324	28424-356

Unit ② —Modulation Oscillator, TM 7467/1

When ordering, prefix circuit reference with 2

C1	Elec 100 $\mu$ F +100-20% 25V	26417-158
C2	Elec 5 $\mu$ F +100-20% 70V	26417-118
C3	Elec 250 $\mu$ F +100-20% 6V	26417-162
C4	Elec 100 $\mu$ F +100-20% 25V	26417-158
C5	Elec 25 $\mu$ F +100-20% 35V	26417-143
C6	Elec 50 $\mu$ F +100-20% 35V	26417-153
C7	Elec 100 $\mu$ F +100-20% 25V	26417-158
C8	Elec 100 $\mu$ F +100-20% 25V	26417-158
MR1	HG-1005	28323-035
MR2	ZB6.2 Zener	28371-486
MR3	HG-1005	28323-035
R1	Met ox 15k $\Omega$ 7% $\frac{3}{8}$ W*	24552-114
R2	Met ox 5.6k $\Omega$ 7% $\frac{3}{8}$ W*	24552-103
R3	Carbon 12k $\Omega$ 10% $\frac{1}{2}$ W	24342-112
R4	Met ox 1.2k $\Omega$ 7% $\frac{3}{8}$ W*	24552-082
R5	Carbon 10k $\Omega$ 10% $\frac{1}{2}$ W	24342-110
R6	Carbon 1.5k $\Omega$ 10% $\frac{1}{2}$ W	24342-084

For symbols and abbreviations see introduction to this chapter

When ordering, prefix circuit reference with 2

Circuit reference	Description	M.I. code
R7	Met ox 2.4k $\Omega$ 7% $\frac{3}{8}W^*$	24552-089
R8	Carb 1k $\Omega$ 10% $\frac{1}{2}W$	24342-080
R9	Carb 4.7k $\Omega$ 10% $\frac{1}{2}W$	24342-100
R10	Met ox 120k $\Omega$ 7% $\frac{3}{8}W^*$	24552-137
R11	Met ox 12k $\Omega$ 7% $\frac{3}{8}W^*$	24552-112
R12	Carb 22k $\Omega$ 7% $\frac{1}{2}W$	24342-118
R13	Carb 2.7k $\Omega$ 10% $\frac{1}{2}W$	24342-092
R14	Carb 220 $\Omega$ 10% $\frac{1}{2}W$	24342-058
R15	Carb 680 $\Omega$ 10% $\frac{1}{2}W$	24342-076
R16	Met ox 5.1k $\Omega$ 7% $\frac{3}{8}W^*$	24552-101
R17 †	Met ox 6.2k $\Omega$ 5% $\frac{1}{2}W$	24332-105
R18	Carb 4.7k $\Omega$ 10% $\frac{1}{2}W$	24342-126
RV1	Carb 2.2k $\Omega$ 20% $\frac{1}{4}W$	25611-018
RV2	Carb 2.2k $\Omega$ 20% $\frac{1}{4}W$	25611-018
RV3	Carb 100 $\Omega$ 20% $\frac{1}{4}W$	25611-002
VT1	BCY71	28435-235
VT2	BCY71	28435-235
VT3	2N404	44522-004
VT4	HT101	28432-735
VT5	BCY71	28435-235

**Unit ③ —A.M./F.M. Drive and Monitor, TM 9057**

When ordering, prefix circuit reference with 3

C1	Elec 100 $\mu F$ +100-20% 6V	26417-154
C3	Plas 0.47 $\mu F$ 10% 250V	26512-264
C4	Plas 0.47 $\mu F$ 10% 250V	26512-264
C5	Plas 2 $\mu F$ 10% 250V	26512-288
C6 †	Plas 820pF 2% 125V	26516-462
C7	Cer 0.1 $\mu F$ +50-25% 30V	26383-031
MR1	1S44	28357-548
MR2	1S44	28357-548
MR3	1S44	28357-548
MR4	1S44	28357-548
MR5	1S44	28357-548
MR6	1S44	28357-548

When ordering, prefix circuit reference with 3

Circuit reference	Description	M.I. code
MR7	1S44	28357-548
MR8	1S44	28357-548
MR9	1S44	28357-548
MR10	1S44	28357-548
R1	Met ox 11k $\Omega$ 7% $\frac{3}{8}W^*$	24552-111
R2	Met ox 18k $\Omega$ 7% $\frac{3}{8}W^*$	24552-116
R3	Met ox 4.7k $\Omega$ 7% $\frac{3}{8}W^*$	24552-126
R4	Met ox 4.3k $\Omega$ 7% $\frac{3}{8}W^*$	24552-097
R5	Met ox 220 $\Omega$ 7% $\frac{3}{8}W^*$	24552-058
R6	Met ox 3.6k $\Omega$ 7% $\frac{3}{8}W^*$	24552-095
R7	Met ox 270 $\Omega$ 7% $\frac{3}{8}W^*$	24552-061
R8	Met ox 1M $\Omega$ 10% $\frac{1}{2}W$	24552-166
R9	Met ox 220k $\Omega$ 7% $\frac{3}{8}W^*$	24552-143
R10	Met ox 4.7k $\Omega$ 7% $\frac{3}{8}W^*$	24552-126
R11	Met ox 10M $\Omega$ 10% $\frac{1}{2}W$	24342-191
R12	Met ox 1M $\Omega$ 10% $\frac{1}{2}W$	24552-166
R13	Met ox 33k $\Omega$ 7% $\frac{3}{8}W^*$	24552-122
R14	Carb 470k $\Omega$ 10% $\frac{1}{2}W$	24342-152
R15	Met ox 9.1k $\Omega$ 7% $\frac{3}{8}W^*$	24552-109
R16	Met ox 10k $\Omega$ 7% $\frac{3}{8}W^*$	24552-110
R17	Met ox 10k $\Omega$ 7% $\frac{3}{8}W^*$	24552-110
R18	Met ox 22k $\Omega$ 7% $\frac{3}{8}W^*$	24552-118
R19	Met ox 1k $\Omega$ 7% $\frac{3}{8}W^*$	24552-080
R20	Met ox 100k $\Omega$ 7% $\frac{3}{8}W^*$	24552-135
R21	Met ox 4.7k $\Omega$ 7% $\frac{3}{8}W^*$	24552-100
R22	Met ox 220 $\Omega$ 7% $\frac{3}{8}W^*$	24552-058
RV1	Carb 4.7k $\Omega$ 20% $\frac{1}{4}W$	25611-034
RV2	Carb 4.7k $\Omega$ 20% $\frac{1}{4}W$	25611-034
RV3	Carb 4.7k $\Omega$ 20% $\frac{1}{4}W$	25611-034
RV4	Carb 2.2k $\Omega$ 20% $\frac{1}{4}W$	25611-018
RV5	Carb 10k $\Omega$ 20% $\frac{1}{4}W$	25611-025
RV6	Carb 2.2M $\Omega$ 20% $\frac{1}{2}W$	25611-054
TH1	CZ3 1.5k $\Omega$	25683-644
TH2	CZ3 1.5k $\Omega$	25683-644

For symbols and abbreviations see introduction to this chapter



When ordering, prefix circuit reference with 3

Circuit reference	Description	M.I. code
VT1	BCY33	28434-217
VT2	BSX20	28452-197
VT3	2N2924	28453-552
VT4	2N2924	28453-552
VT5	BSX20	28452-197
VT6	BSX20	28452-197
VT7	2N3702	28433-488
VT8	BSX20	28452-197
VT9	2N3702	28433-488

When ordering, prefix circuit reference with 4

Circuit reference	Description	M.I. code
R17	Met ox 2.2k $\Omega$ 7% $\frac{3}{8}$ W*	24552-088
R18	Met ox 1k $\Omega$ 7% $\frac{3}{8}$ W*	24552-080
R19	Met ox 330 $\Omega$ 7% $\frac{3}{8}$ W*	24552-063
R20 †	Met ox 33 $\Omega$ 7% $\frac{3}{8}$ W*	24552-033
R21	Met ox 4.7k $\Omega$ 7% $\frac{3}{8}$ W*	24552-100
R22	Met ox 1k $\Omega$ 7% $\frac{3}{8}$ W*	24552-080
R23	Met ox 4.3k $\Omega$ 7% $\frac{3}{8}$ W*	24552-097
R24	Met ox 2k $\Omega$ 7% $\frac{3}{8}$ W*	24552-087
R25	Met ox 510 $\Omega$ 7% $\frac{3}{8}$ W*	24552-071
R26	Met ox 1k $\Omega$ 7% $\frac{3}{8}$ W*	24552-080
R27	Met ox 220 $\Omega$ 7% $\frac{3}{8}$ W*	24552-058
R28	Met ox 220k $\Omega$ 7% $\frac{3}{8}$ W*	24552-143

### Unit (4) —Regulated Power Supply and Monitor Amp., TM 9056

When ordering, prefix circuit reference with 4

C1	Elec 100 $\mu$ F +100-20% 25V	26417-158	RV1	WW 500 $\Omega$ 10% $\frac{1}{2}$ W	25886-717
C2	Elec 100 $\mu$ F +100-20% 25V	26417-158	RV2	Carb 1k $\Omega$ 20% $\frac{1}{4}$ W	25611-014
C3	Elec 25 $\mu$ F +100-20% 35V	26417-143	RV3	Carb 2.2k $\Omega$ 20% $\frac{1}{4}$ W	25611-206
C4	Elec 100 $\mu$ F +100-20% 25V	26417-158	RV4	Carb 100 $\Omega$ 10% 1W	25811-013
C5	Elec 10 $\mu$ F +50-20% 35V	26414-121	RV5	Carb 470 $\Omega$ 20% $\frac{1}{4}$ W	25611-010
MR1	ZB7.5 5% Zener	28371-606	RV6	Carb 470 $\Omega$ 20% $\frac{1}{4}$ W	25611-010
R1	Met ox 470 $\Omega$ 7% $\frac{3}{8}$ W*	24552-069	RV7	Carb 4.7k $\Omega$ 20% $\frac{1}{4}$ W	25611-022
R2	Met ox 4.7k $\Omega$ 7% $\frac{3}{8}$ W*	24552-100	RV8	Carb 100 $\Omega$ 10% 1W	25811-013
R3	Met ox 2.2k $\Omega$ 7% $\frac{3}{8}$ W*	24552-088	RV9	Carb 220 $\Omega$ 20% $\frac{1}{4}$ W	25611-244
R4	Met ox 820 $\Omega$ 7% $\frac{3}{8}$ W*	24552-078	TH1	CZ3 1.5k $\Omega$	25683-644
R5	Met ox 330 $\Omega$ 7% $\frac{3}{8}$ W*	24552-063	VT1	ACY20	28424-747
R6	Met ox 330 $\Omega$ 7% $\frac{3}{8}$ W*	24552-063	VT2	2S701	28453-488
R7	Met ox 1k $\Omega$ 7% $\frac{3}{8}$ W*	24552-080	VT3	BCY34	28434-227
R8	Met ox 7.5k $\Omega$ 7% $\frac{3}{8}$ W*	24552-107	VT4	BSX20	28452-197
R9	Met ox 12k $\Omega$ 7% $\frac{3}{8}$ W*	24552-112	VT5	BSX20	28452-197
R10	Met ox 4.7k $\Omega$ 7% $\frac{3}{8}$ W*	24552-100	VT6	2N3702	28433-488
R11	Met ox 5.1k $\Omega$ 7% $\frac{3}{8}$ W*	24552-101	VT7	BSX20	28452-197
R12	Met ox 1.5k $\Omega$ 7% $\frac{3}{8}$ W*	24552-084	VT8	2N3702	28433-488
R13	Met ox 820 $\Omega$ 7% $\frac{3}{8}$ W	24552-078	VT9	2N3702	28433-488
R14	Met ox 1k $\Omega$ 7% $\frac{3}{8}$ W*	24552-080	VT10	BSX20	28452-197
R15	Met ox 18k $\Omega$ 7% $\frac{3}{8}$ W*	24552-116			
R16	Met ox 2k $\Omega$ 7% $\frac{3}{8}$ W*	24552-087			

For symbols and abbreviations see introduction to this chapter

**Unit ⑤ —Crystal Calibrator Amplifier, TM 7190**

When ordering, prefix circuit reference with 5

Circuit reference	Description	M.I. code
C1	Elec 5 $\mu$ F +100-20% 70V	26417-118
C2	Elec 50 $\mu$ F +100-20% 6V	26412-245
C3	Elec 1 $\mu$ F +100-20% 50V	26414-106
C4	Elec 100 $\mu$ F +100-20% 25V	26417-158
C5	Elec 1 $\mu$ F +100-20% 50V	26414-106
C6	Plas 0.1 $\mu$ F 10% 250V	26582-208
C7	Elec 250 $\mu$ F +100-20% 6V	26417-162
C8	Elec 25 $\mu$ F +100-20% 35V	26417-143
C9	Plas 0.047 $\mu$ F $\frac{1}{2}$ % 125V	26516-820
C10	Plas 0.047 $\mu$ F $\frac{1}{2}$ % 125V	26516-820
L1	285mH	44273-607
R1	Carb 4.7k $\Omega$ 10% $\frac{1}{2}$ W	24342-126
R2	Carb 4.7k $\Omega$ 10% $\frac{1}{2}$ W	24342-126
R3	Carb 10k $\Omega$ 10% $\frac{1}{2}$ W	24342-110
R4	Carb 10k $\Omega$ 10% $\frac{1}{2}$ W	24342-110
R5	Carb 3.3k $\Omega$ 10% $\frac{1}{2}$ W	24342-094
R6	Carb 1k $\Omega$ 10% $\frac{1}{2}$ W	24342-080
R7	Carb 4.7k $\Omega$ 10% $\frac{1}{2}$ W	24342-100
R8	Carb 330k $\Omega$ 10% $\frac{1}{2}$ W	24342-148
R9	Carb 1k $\Omega$ 10% $\frac{1}{2}$ W	24342-080
R10	Carb 470 $\Omega$ 10% $\frac{1}{2}$ W	24342-059
R11	Carb 22k $\Omega$ 10% $\frac{1}{2}$ W	24342-118
R12	Met ox 330 $\Omega$ 7% $\frac{3}{4}$ W*	24552-063
RV1	Carb 4.7k $\Omega$ 20% $\frac{1}{4}$ W	25611-022
RV2	Carb 470 $\Omega$ 20% $\frac{1}{4}$ W	25611-010
VT1	ACY20	28424-747
VT2	2S701	29453-488
VT3	ACY20	28424-747

**Unit ⑥ —Crystal Calibrator, TM 9369**

When ordering, prefix circuit reference with 6

Circuit reference	Description	M.I. code
C1	Elec 10 $\mu$ F +50-20% 35V	26414-121
C2 †	Plas 27pF $\pm$ 2pF 125V	26516-108
C3	Plas 470pF 2% 125V	26516-406
C4	Plas 0.0022 $\mu$ F 2% 125V	26516-564
C5	Plas 470pF 2% 125V	26516-406
C6	Plas 27pF $\pm$ 2pF 125V	26516-108
C7	Plas 0.0028 $\mu$ F 2% 125V	26516-591
C8	Paper 0.01 $\mu$ F 10% 200V	26174-145
C9	Cer 0.1 $\mu$ F +50-25% 30V	26383-031
C10	Plas 180pF 2% 125V	26516-303
C11	Cer 0.01 $\mu$ F +80-20% 100V	26383-055
C12	Plas 150pF 2% 125V	26516-287
C13	Cer 22pF $\pm$ 0.25pF 750V	26324-715
C14	Plas 82pF $\pm$ 2pF 125V	26516-222
C15	Plas 22pF $\pm$ 2pF 125V	26516-088
C16	Plas 0.001 $\mu$ F 2% 125V	26516-481
C17	Plas 110pF 2% 125V	26516-254
C18	Plas 0.001 $\mu$ F 2% 125V	26516-481
C19 †	Plas 390pF 2% 125V	26516-387
C20	Elec 10 $\mu$ F +50-20% 35V	26414-121
C21	Cer 0.1 $\mu$ F +50-25% 30V	26383-031
C22	Plas 0.01 $\mu$ F 1% 125V	26516-718
C23	Plas 220pF 5% 125V	26516-328
C24	Elec 10 $\mu$ F +50-20% 35V	26414-121
C25	Cer 0.01 $\mu$ F +80-20% 100V	26383-055
C26	Cer 22pF $\pm$ 0.25pF 750V	26324-715
C27	Cer 0.1 $\mu$ F +50-25% 30V	26383-031
C28	Plas 120pF $\pm$ 2pF 125V	26516-264
C29	Cer 0.1 $\mu$ F +50-25% 30V	26383-031

For symbols and abbreviations see introduction to this chapter

When ordering, prefix circuit reference with 6

Circuit reference	Description	M.I. code
C30	Cer 0.1 $\mu$ F +50-25% 30V	26383-031
C31	Cer 0.1 $\mu$ F +50-25% 30V	26383-031
C32	Cer 0.1 $\mu$ F +50-25% 30V	26383-031
C33	Elec 10 $\mu$ F +50-20% 35V	26414-121
C34	Var air 3-12pF +20-0% 500V	26816-236
L1	63.5 $\mu$ H	44264-210
L2	237 $\mu$ H	44266-217
L3	Coil	44123-403
L4	470 $\mu$ H	23642-565
L5	470 $\mu$ H	23642-565
L6	470 $\mu$ H	23642-565
L7	470 $\mu$ H	23642-565
MR1	1N916	28336-466
MR2	1N916	28336-466
MR3	1N916	28336-466
MR4	1N916	28336-466
MR5	1N916	28336-466
MR6	1N916	28336-466
MR7	1N916	28336-466
R1	Met ox 24k $\Omega$ 7% $\frac{3}{8}$ W	24552-119
R2	Met ox 9.1k $\Omega$ 7% $\frac{3}{8}$ W*	24552-109
R3	Met ox 2k $\Omega$ 7% $\frac{3}{8}$ W*	24552-087
R4	Met ox 47 $\Omega$ 7% $\frac{3}{8}$ W*	24552-037
R5	Met ox 100 $\Omega$ 7% $\frac{3}{8}$ W*	24552-050
R6	Met ox 560 $\Omega$ 7% $\frac{3}{8}$ W*	24552-072
R7	Met ox 220 $\Omega$ 7% $\frac{3}{8}$ W*	24552-058
R8	Met ox 100 $\Omega$ 7% $\frac{3}{8}$ W*	24552-050

When ordering, prefix circuit reference with 6

Circuit reference	Description	M.I. code
R9	Met ox 100 $\Omega$ 7% $\frac{3}{8}$ W*	24552-050
R10	Met ox 10 $\Omega$ 7% $\frac{3}{8}$ W*	24552-020
R11	Met ox 3.9k $\Omega$ 7% $\frac{3}{8}$ W*	24552-096
R12	Met ox 4.7k $\Omega$ 7% $\frac{3}{8}$ W*	24552-100
R13	Met ox 470 $\Omega$ 7% $\frac{3}{8}$ W*	24552-069
R14	Met ox 1 $\Omega$ 10% $\frac{3}{8}$ W*	24582-555
R15	Met ox 100 $\Omega$ 7% $\frac{3}{8}$ W*	24552-050
R16	Met ox 100 $\Omega$ 7% $\frac{3}{8}$ W*	24552-050
R17	Met ox 220 $\Omega$ 7% $\frac{3}{8}$ W*	24552-058
R18	Met ox 470 $\Omega$ 7% $\frac{3}{8}$ W*	24552-069
R19	Met ox 3.9k $\Omega$ 7% $\frac{3}{8}$ W*	24552-096
R20	Met ox 4.7k $\Omega$ 7% $\frac{3}{8}$ W*	24552-100
R21	Met ox 5.1k $\Omega$ 3% $\frac{3}{8}$ W*	24512-402
R22	Met ox 330 $\Omega$ 3% $\frac{3}{8}$ W*	24512-363
R23	Met ox 180 $\Omega$ 3% $\frac{3}{8}$ W*	24512-356
R24	Met ox 5.1k $\Omega$ 3% $\frac{3}{8}$ W*	24512-402
R25	Met ox 560 $\Omega$ 3% $\frac{3}{8}$ W*	24512-372
R26	Met ox 680 $\Omega$ 3% $\frac{3}{8}$ W*	24512-376
R27	Met ox 220 $\Omega$ 3% $\frac{3}{8}$ W*	24512-358
R28	Met ox 2.2k $\Omega$ 7% $\frac{3}{8}$ W*	24552-088
R29	Met ox 100 $\Omega$ 7% $\frac{3}{8}$ W*	24552-050
R30	Met ox 470 $\Omega$ 7% $\frac{3}{8}$ W*	24552-069
R31	Met ox 47 $\Omega$ 7% $\frac{3}{8}$ W*	24552-037
R32	Met ox 1k $\Omega$ 7% $\frac{3}{8}$ W*	24552-080
R33	Met ox 3.3k $\Omega$ 7% $\frac{3}{8}$ W	24552-094
R34	Met ox 1k $\Omega$ 7% $\frac{3}{8}$ W*	24552-080
R35	Met ox 12k $\Omega$ 7% $\frac{3}{8}$ W*	24552-112
R36	Met ox 33 $\Omega$ 7% $\frac{3}{8}$ W*	24552-033
R37	Met ox 1k $\Omega$ 7% $\frac{3}{8}$ W*	24552-080

For symbols and abbreviations see introduction to this chapter

Replaceable parts

When ordering, prefix circuit reference with 6

Circuit reference	Description	M.I. code
VT1	2N3904	28454-786
VT2	2N3904	28454-786
VT3	BSX20	28452-197
VT4	2N3702	28433-488
VT5	BSX20	28452-197
VT6	BSX20	28452-197
VT7	2N3702	28433-488
VT8	BSX20	28452-197
VT9	BC108	28452-787
VT10	BC108	28452-787
VT11	BSX20	28452-197
VT12	MPS3640	28431-766
VT13	BSX20	28452-197

When ordering, prefix circuit reference with 7

Circuit reference	Description	M.I. code
C8	Cer 0.1 $\mu$ F +50-25% 30V	26383-031
C9 †	Plas 0.0018 $\mu$ F 2% 125V	26516-543
C10	Plas 0.00366 $\mu$ F 1% 125V	26516-620
L1	120mH 25%	44267-603
L2	120mH 25%	44267-603
L3	120mH 25%	44267-603
L4	34.0mH 25%	44271-604
L5	1mH 25%	44245-003
L6	1mH 25%	44245-003
L7	120mH 25%	44267-603
L8	120mH 25%	44267-603
L9	45.5mH 1%	44267-606
L10	11.8mH 2%	44268-603

X1	1000kHz	28311-703
----	---------	-----------

Unit 8 — Filters, TM 9055

When ordering, prefix circuit reference with 8

C1	Cer 0.1 $\mu$ F +50-25% 30V	26383-031
C2	Cer 0.1 $\mu$ F +50-25% 30V	26383-031
C3	Cer 0.1 $\mu$ F +50-25% 30V	26383-031
C4	Plas 0.1 $\mu$ F 10% 250V	26582-208
C5	Cer 0.1 $\mu$ F +50- 5% 30V	26383-031
C6	Cer 0.1 $\mu$ F +50-25% 30V	26383-031
C7	Cer 0.1 $\mu$ F +50-25% 30V	26383-031
C8	Cer 0.1 $\mu$ F +50-25% 30V	26383-031
C9 †	Plas 0.0026 $\mu$ F 2% 125V	26516 587
C10	Plas 0.0108 $\mu$ F 1% 125V	26516-901
C11	Plas 0.02 $\mu$ F 2% 125V	26516-797
C13	Paper 0.001 $\mu$ F 20% 600V	26174-125
C14	Cer 0.1 $\mu$ F +50-25% 30V	26383-031
C15	Cer 0.1 $\mu$ F +50-25% 30V	26383-031
C16	Cer 0.1 $\mu$ F +50-25% 30V	26383-031
C17	Plas 0.1 $\mu$ F 10% 250V	26582-208
C18	Cer 0.1 $\mu$ F +50-25% 30V	26383-031

Unit 7 — Filters, TM 9054

When ordering, prefix circuit reference with 7

C1	Cer 0.1 $\mu$ F +50-25% 30V	26383-031
C2	Cer 0.1 $\mu$ F +50-25% 30V	26383-031
C3	Cer 0.1 $\mu$ F +50-25% 30V	26383-031
C4	Plas 0.047 $\mu$ F 10% 250V	26582-206
C5	Cer 0.1 $\mu$ F +50-25% 30V	26383-031
C6	Cer 0.1 $\mu$ F +50-25% 30V	26383-031
C7	Cer 0.1 $\mu$ F +50-25% 30V	26383-031

For symbols and abbreviations see introduction to this chapter

When ordering, prefix circuit reference with 8

Circuit reference	Description	M.I. code
J19	Cer 0.1 $\mu$ F +50-25% 30V	26383-031
G20	Cer 0.1 $\mu$ F +50-25% 30V	26383-031
G21	Cer 0.1 $\mu$ F +50-25% 30V	26383-031
G22	Plas 0.0118 $\mu$ F 2% 125V	26516-722
G24 †	Plas 820pF nom.	26516-462
G26	Plas 0.0075 $\mu$ F 1% 125V	26516-689
L1	120mH 25%	44267-603
L2	120mH 25%	44267-603
L3	120mH 25%	44267-603
L4	34.0mH 25%	44271-604
L5	1mH 25%	44245-003
L6	1mH 25%	44245-003
L7	120mH 25%	44267-603
L8	120mH 25%	44267-603
L9	37.7mH 1%	44267-604
L10	15.1mH 2%	44268-602
L11	330mH 25%	44271-606
R1 †	Met ox 120k $\Omega$ 7% $\frac{3}{8}$ W*	24552-137
R2 †	Met ox 100k $\Omega$ 7% $\frac{3}{8}$ W*	24552-135

**Unit ⑩ —Range B Oscillator, TM 7562**

When ordering, prefix circuit reference with 10

Circuit reference	Description	M.I. code
C1	Cer 0.1 $\mu$ F +50-25% 25V	26383-031
C2	Plas 0.01 $\mu$ F 2% 50V	26518-053
C3	Plas 0.33 $\mu$ F 5% 125V	26511-367
C5 †	Plas 0.001 $\mu$ F 2% 125V	26516-481
C6	Plas 0.33 $\mu$ F 5% 125V	26511-367
C7	Plas 0.1 $\mu$ F 10% 250V	26582-208
L1	Tuning coil	44267-001
L2	Trimmer	44264-205
R1	Met ox 3.3k $\Omega$ 7% $\frac{3}{8}$ W*	24552-094
R2	Met ox 1k $\Omega$ 7% $\frac{3}{8}$ W*	24552-080
R3	Met ox 1k $\Omega$ 7% $\frac{3}{8}$ W*	24552-080
R4	Met ox 820 $\Omega$ 7% $\frac{3}{8}$ W*	24552-078
R5	Met ox 100 $\Omega$ 7% $\frac{3}{8}$ W*	24552-050
VT1	ACY20	28424-747

**Unit ⑨ —Range A Oscillator, TM 7561**

When ordering, prefix circuit reference with 9

C1	Cer 0.1 $\mu$ F +50-25% 25V	26383-031
C2	Plas 0.11 $\mu$ F 2% 125V	26518-293
C3	Plas 1 $\mu$ F 5% 125V	26511-382
C5 †	Plas 0.047 $\mu$ F 5% 125V	26511-337
C6	Plas 1 $\mu$ F 5% 125V	26511-382
C7	Cer 0.1 $\mu$ F +50-25% 25V	26383-031
L1	Tuning coil	44267-001
L2	Trimmer	44264-705
R1	Met ox 3.3k $\Omega$ 7% $\frac{3}{8}$ W*	24552-094
R2	Met ox 1k $\Omega$ 7% $\frac{3}{8}$ W*	24552-080
R3	Met ox 1k $\Omega$ 7% $\frac{3}{8}$ W*	24552-080
R4	Met ox 1k $\Omega$ 7% $\frac{3}{8}$ W*	24552-080
R5	Met ox 100 $\Omega$ 7% $\frac{3}{8}$ W*	24552-050
VT1	ACY20	28424-747

**Unit ⑪ —Range C Oscillator, TM 9048**

When ordering, prefix circuit reference with 11

C1	Plas 0.0028 $\mu$ F 2% 125V	26516-481
C2	Plas 100pF $\pm$ 2pF 125V	26516-241
C3 †	Plas 0.015 $\mu$ F 5% 125V	26511-319
C4	Plas 0.003 $\mu$ F 2% 125V	26516-597
C5	Cer 0.1 $\mu$ F +50-25% 25V	26383-031
C6 †	Plas 300pF 2% 125V	26516-358
C7	Plas 0.033 $\mu$ F 5% 125V	26511-330
C8	Plas 0.1 $\mu$ F 5% 125V	26511-349
C9	Plas 0.0068 $\mu$ F 5% 160V	26511-164
L1	Tuning coil	44265-204
L2	Trimmer	44257-211
R1	Met ox 4.7k $\Omega$ 7% $\frac{3}{8}$ W*	24552-100
R2	Met ox 6.8k $\Omega$ 7% $\frac{3}{8}$ W*	24552-106

For symbols and abbreviations see introduction to this chapter

When ordering, prefix circuit reference with 11

Circuit reference	Description	M.I. code
R3	Met ox 1k $\Omega$ 7% $\frac{3}{8}$ W*	24552-080
R4	Met ox 3.3k $\Omega$ 7% $\frac{3}{8}$ W*	24552-094
R5	Met ox 1.3k $\Omega$ 7% $\frac{3}{8}$ W*	24552-083
R6	Met ox 1.5k $\Omega$ 7% $\frac{3}{8}$ W*	24552-084
VT1	BSX20	28452-197
VT2	BSX20	28452-197

### Unit (12) —Range D Oscillator, TM 9049

When ordering, prefix circuit reference with 12

C1	Plas 0.001 $\mu$ F 2% 125V	26516-481
C2	Plas 68pF 2% 125V	26516-201
C3	Plas 0.033 $\mu$ F $\pm$ 10% 250V	26582-205
C4	Plas 0.001 $\mu$ F 2% 125V	26516-481
C5	Cer 0.1 $\mu$ F +50-25% 25V	26383-031
C6 †	Plas 100pF $\pm$ 2pF 125V	26516-241
C7	Plas 0.01 $\mu$ F 5% 125V	26511-313
C8	Plas 0.033 $\mu$ F 5% 125V	26511-330
L1	Tuning coil	44263-035
L2	Trimmer	44247-010
R1	Met ox 470 $\Omega$ 7% $\frac{3}{8}$ W*	24552-069
R2	Met ox 4.7k $\Omega$ 7% 3/8W*	24552-100
R3	Met ox 4.7k $\Omega$ 7% $\frac{3}{8}$ W*	24552-100
R4	Met ox 3.3k $\Omega$ 7% $\frac{3}{8}$ W*	24552-094
R5	Met ox 1.5k $\Omega$ 7% $\frac{3}{8}$ W*	24552-084
R6	Met ox 1.5k $\Omega$ 7% $\frac{3}{8}$ W*	24552-084
VT1	BSX20	28452-197
VT2	BSX20	28452-197

### Unit (13) —Range E Oscillator, TM 9047

When ordering, prefix circuit reference with 13

Circuit reference	Description	M.I. code
C1	Plas 1000pF 2% 125V	26516-481
C2	Cer 33pF 5% 750V	26324-822
C3	Cer 0.1 $\mu$ F +50-25% 30V	26383-031
C4	Mica 330pF 5% 350V	26268-391
C5 †	Cer 22pF 5% 750V	26324-833
C6	Plas 0.0033 $\mu$ F 2% 125V	26516-609
C7	Cer 0.1 $\mu$ F +50-25% 30V	26383-031
C8	Plas 0.0033 $\mu$ F 2% 125V	26516-609
C9	Plas 0.068 $\mu$ F $\pm$ 10% 250V	26582-207
L1	Coil assy.	44255-005
L2	Coil assy.	44233-014
R1	Met ox 47 $\Omega$ 7% $\frac{3}{8}$ W*	24552-037
R2	Met ox 1k $\Omega$ 7% $\frac{3}{8}$ W*	24552-080
R3	Met ox 3.3k $\Omega$ 7% $\frac{3}{8}$ W*	24552-094
R4	Met ox 10k $\Omega$ 7% $\frac{3}{8}$ W*	24552-110
R5	Met ox 10k $\Omega$ 7% $\frac{3}{8}$ W*	24552-110
VT1	BSX20	28452-197
VT2	BSX20	28452-197

### Unit (14) —Range F Oscillator, TM 9050

When ordering, prefix circuit reference with 14

C1	Plas 0.0015 $\mu$ F 2% 125V	26516-524
C2	Cer 15pF 0.25pF 750V	26324-822
C3	Cer 0.1 $\mu$ F +50-25% 30V	26383-031
C4	Mica 330pF 2% 350V	26268-391
C5 †	Cer 22pF 5% 750V	26324-833
C6	Plas 0.0033 $\mu$ F 2% 125V	26516-609
C7	Cer 0.1 $\mu$ F +50-25% 30V	26383-031
C8	Plas 0.0033 $\mu$ F 2% 125V	26516-609
C9	Plas 0.047 $\mu$ F 10% 250V	26582-206

For symbols and abbreviations see introduction to this chapter

When ordering, prefix circuit reference with 14

Circuit reference	Description	M.I. code
L1	Coil assy.	44237-003
L2	Coil assy.	44223-202
R1	Met ox 4.7Ω 7% $\frac{3}{8}W^*$	24552-037
R2	Met ox 1kΩ 7% $\frac{3}{8}W^*$	24552-080
R3	Met ox 3.3kΩ 7% $\frac{3}{8}W^*$	24552-094
R4	Met ox 4.7kΩ 7% $\frac{3}{8}W^*$	24552-100
R5	Met ox 18kΩ 7% $\frac{3}{8}W^*$	24552-116
VT1	BSX20	28452-197
VT2	BSX20	28452-197

**Unit (15) —Range G Oscillator, TM 9052**

When ordering, prefix circuit reference with 15

C1	Cer 0.01μF +80-20% 350V	26383-392
C2	Plas 0.0015μF 2% 125V	26516-524
C3	Cer 0.01μF +80-20% 350V	26383-392
C4	Cer 100pF 2% 750V	26324-897
C5	Mica 68pF 1% 350V	26268-317
C6 †	Cer 10pF ±0.5pF 750V	26324-085
C7	Mica 500pF 5% 350V	26258-392
C8	Cer 0.01μF +80-20% 350V	26383-392
C9	Mica 0.001μF 1% 350V	26268-350
C10	Mica 100pF 5% 350V	26268-325
C11	Cer 0.01μF +80-20% 350V	26383-392
L1	Filter	44221-803
L3	Tuning coil	44133-901
L4	Trimmer	44233-901
MR1	V47	28381-135
R1	Met ox 3.3kΩ 7% $\frac{3}{8}W^*$	24552-094
R2	Met ox 1kΩ 7% $\frac{3}{8}W^*$	24552-080
R3	Met ox 1kΩ 7% $\frac{3}{8}W^*$	24552-094
R4	Met ox 100Ω 7% $\frac{3}{8}W^*$	24552-050
R5	Met ox 330Ω 7% $\frac{3}{8}W^*$	24552-063

When ordering, prefix circuit reference with 15

Circuit reference	Description	M.I. code
R6	Met ox 4.70Ω 7% $\frac{3}{8}W^*$	24552-069
R7	Met ox 4.7kΩ 7% $\frac{3}{8}W^*$	24552-100
R8	Met ox 12kΩ 7% $\frac{3}{8}W^*$	24552-112
VT1	BSY28	28451-713
VT2	BFY18	28453-533

**Unit (16) —Range H Oscillator, TM 9053**

When ordering, prefix circuit reference with 16

C1	Cer 0.01μF +80-20% 350V	26383-392
C2	Plas 0.0015μF 2% 125V	26516-524
C3	Cer 0.01μF +80-20% 350V	26383-392
C4	Cer 10pF ±0.5pF 750V	26324-085
C5	Cer 1pF ±0.5pF 750V	26324-020
C6	Var air 3-12pF	26817-238
C7	Mica 100pF 5% 350V	26268-325
C8	Cer 0.01μF +80-20% 350V	26383-392
C9	Mica 100pF 5% 350V	26268-325
C10	Mica 33pF 5% 350V	26268-308
C11	Cer 0.1μF +50-20% 25V	26383-031
C12	Cer 33pF 5% 750V	26324-822
L1	Filter	44221-803
L3	Tuning coil	44227-901
L4	Trimmer	44223-202
MR1	BA111	28381-201
R1	Met ox 1.5kΩ 7% $\frac{3}{8}W^*$	24552-084
R2	Met ox 1kΩ 7% $\frac{3}{8}W^*$	24552-080
R3	Met ox 3.3kΩ 7% $\frac{3}{8}W^*$	24552-094
R4	Met ox 100Ω 7% $\frac{3}{8}W^*$	24552-050
R5	Met ox 330Ω 7% $\frac{3}{8}W^*$	24552-063
R6	Met ox 4.70Ω 7% $\frac{3}{8}W^*$	24552-069
R7	Met ox 4.7kΩ 7% $\frac{3}{8}W^*$	24552-100
VT1	BSY28	28451-713
VT2	BSY28	28451-713

For symbols and abbreviations see introduction to this chapter

**Unit (17) —Range A Output Filter, TM 7571**

When ordering, prefix circuit reference with 17

Circuit reference	Description	M.I. code
C1 †	Plas 0.068μF 5% 125V	26511-343
C2	Plas 0.22μF 1% 125V	26511-360
C3	Plas 0.33μF 5% 125V	26511-367
C4	Plas 0.47μF 10% 125V	26511-374
L1	AF filter	44268-418
L2	Trimmer	44253-014
L3	Tuning coil	44265-010

**Unit (18) —Range B Output Filter, TM 7572**

When ordering, prefix circuit reference with 18

C1 †	Plas 0.01μF 5% 125V	26511-313
C2	Plas 0.068μF 5% 125V	26511-343
C3	Plas 0.1μF 5% 125V	26511-349
C4	Plas 0.15μF 5% 125V	26511-356
L1	AF filter	44268-418
L2	Trimmer	44253-014
L3	Tuning coil	44265-010

**Unit (19) —Range C Output Filter, TM 7573**

When ordering, prefix circuit reference with 19

C1 †	Plas 0.0047μF 5% 125V	26511-149
C2	Plas 0.022μF 5% 125V	26511-324
C3	Plas 0.033μF 5% 125V	26511-330
C4	Plas 0.047μF 5% 125V	26511-337
L1	AF filter	44266-407
L2	Trimmer	44237-008
L3	Tuning coil	44263-034

**Unit (20) —Range D Output Filter, TM 7574**

When ordering, prefix circuit reference with 20

Circuit reference	Description	M.I. code
C1 †	Plas 0.001μF 2% 125V	26516-481
C2	Plas 0.068μF 5% 125V	26511-164
C3	Plas 0.01μF 5% 125V	26511-313
C4	Plas 0.015μF 5% 125V	26511-319
L1	AF filter	44264-406
L2	Trimmer	44233-015
L3	Tuning coil	44251-006

**Unit (21) —Range E Output Filter, TM 7575**

When ordering, prefix circuit reference with 21

C1 †	Plas 330pF 2% 125V	26516-369
C2	Plas 0.0022μF 2% 125V	26516-564
C3	Plas 0.0022μF 2% 125V	26516-564
C4	Plas 0.005μF 2% 125V	26516-652
L1	AF filter	23635-473
L2	Trimmer	44227-010
L3	Tuning coil	44241-002

**Unit (22) —Range F Output Filter, TM 7576**

When ordering, prefix circuit reference with 22

C1	Plas 0.001μF 2% 125V	26516-481
C2	Plas 680pF 2% 125V	26516-444
C3 †	Plas 220pF 2% 125V	26516-327
C4	Plas 0.001μF 2% 125V	26516-481
L1	AF filter	44257-210
L2	Trimmer	44223-201
L3	Tuning coil	44237-003

For symbols and abbreviations see introduction to this chapter



**Unit 23 —Range G Output Filter, TM 7577**

When ordering, prefix circuit reference with 25

When ordering, prefix circuit reference with 23

Circuit reference	Description	M.I. code	Circuit reference	Description	M.I. code
C1	Mica 330pF 5% 350V	26268-391	C11	Cer 0.47μF +50-25% 3V	26383-037
C2	Mica 100pF 5% 350V	26268-325	C12	Cer 0.01μF +80-20% 100V	26383-055
C3 †	Cer 33pF 5% 750V	26324-822	C13	Cer 0.01μF +80-20% 100V	26383-055
C4	Mica 330pF 5% 350V	26268-391	C15	Cer 0.1μF +50-25% 25V	26383-031
L1	AF filter	44257-210	C16	Cer 0.01μF +80-20% 100V	26383-055
L2	Trimmer	44223-201	C17	Cer 0.01μF +80-20% 100V	26383-055
L3	Tuning coil	44233-901	C18	Cer 0.1μF +50-25% 30V	26383-031
			FS1	100mA, quick acting	23411-002

**Unit 24 —Range H Output Filter, TM 7578**

When ordering, prefix circuit reference with 24

C1	Mica 100pF 5% 350V	26268-325	L1	Filter	44255-204
C2	Mica 15pF ±1pF 350V	26268-302	L2	Ferrite bead	44223-801
C3	Var air 3-12pF	26817-238	L3	Ferrite bead	44223-801
C4	Mica 100pF 5% 350V	26268-325	L4	Coil assy.	44121-805
L1	AF filter	44257-210	L5	Coil assy.	44121-805
L2	Trimmer	44223-202	MR1	Z4B5.6 Zener	28371-435
L3	Tuning coil	44227-901	MR2	Z4B4.3 Zener	28371-321

**Unit 25 —Wide Band Amplifier, TM 7189**

When ordering, prefix circuit reference with 25

C1	Cer 0.1μF +50-25% 25V	26383-031	R1	Carb 33Ω 10% 1/2W	24342-033
C2	Elec 10μF +100-20% 35V	26414-121	R2	Carb 33Ω 10% 1/2W	24342-033
C3	Cer 33pF 5% 750V	26324-822	R3	Carb 33Ω 10% 1/2W	24342-033
C4	Elec 10μF +100-20% 35V	26414-121	R4	Carb 1kΩ 10% 1/2W	24342-080
C5	Elec 5μF +100-20% 15V	26414-113	R5	Carb 3.9kΩ 10% 1/2W	24342-096
C6	Elec 5μF +100-20% 15V	26414-113	R6	Met ox 240Ω 7% 3/8W*	24552-060
C7	Elec 10μF +100-20% 35V	26414-121	R7	Carb 1kΩ 10% 1/2W	24342-080
C8	Cer 0.47μF +50-25% 3V	26383-037	R8	Met ox 2kΩ 7% 3/8W*	24552-087
C9	Cer 0.47μF +50-25% 3V	26383-037	R9	Carb 820Ω 10% 1/2W	24342-078
C10	Cer 0.47μF +50-25% 3V	26383-037	R10	Met ox 240Ω 7% 3/8W*	24552-060
			R11	Carbon 470Ω 10% 1/2W*	24342-069
			R12	Carb 1kΩ 10% 1/2W*	24342-080
			R13	WW 47Ω 5% 1 1/2W	25123-037
			R14	WW 47Ω 5% 1 1/2W	25123-037
			R15	Carb 100Ω 10% 1/2W*	24342-050
			R16	Carb 100Ω 10% 1/2W*	24342-050
			R17	WW 47Ω 5% 1 1/2W*	25123-037
			R18	WW 47Ω 5% 1 1/2W*	25123-037
			R19	Carb 220Ω 10% 1/2W*	24342-058
			R20	Carb 220Ω 10% 1/2W*	24342-058

For symbols and abbreviations see introduction to this chapter

When ordering, prefix circuit reference with 25

When ordering, prefix circuit reference with 26

Circuit reference	Description	M.I. code	Circuit reference	Description	M.I. code
R21	Carb 220Ω 10% 1/2W*	24342-058	MR1	HG5004	28332-465
R22	Carb 220Ω 10% 1/2W*	24342-058	MR2	HG5004	28332-465
R23	WW 2.2kΩ 5% 1 1/2W	25123-088	MR3	CG92H	28321-161
R24	WW 2.2kΩ 5% 1 1/2W	25123-088	MR4	CG92H	28321-161
R25	Carb 56Ω 10% 1/2W	24341-240			
T1	1:1 unbal to bal	43548-001	R1	Met ox 7.5kΩ 7% 3/8W*	24552-107
T2	Driver	43535-011	R2	Met ox 8.2kΩ 7% 3/8W*	24552-108
T3	Driver	43537-001	R3	Met ox 6.8kΩ 7% 3/8W*	24552-106
T4	2:1 bal to unbal	43557-001	R4	Met ox 560Ω 7% 3/8W*	24552-072
T5	2:1 bal to unbal	43535-010	R5	Met ox 2.2kΩ 7% 3/8W*	24552-088
			R6	Met ox 2.2kΩ 7% 3/8W*	24552-088
VT1	BSY29	28451-716	R7	Met ox 1.5kΩ 7% 3/8W*	24552-084
VT2	BSY29	28451-716	R8	Met ox 3.3kΩ 7% 3/8W*	24552-094
VT3	BSY29 } matched pair	44522-031	R10	Met ox 8.2kΩ 7% 3/8W*	24552-108
VT4			BSY29	R12	Met ox 5.1kΩ 7% 3/8W*
VT5	BSY29 } matched pair	44522-031	R13	Met ox 5.1kΩ 7% 3/8W*	24552-101
VT6			BSY29	R14	Carb 2.2kΩ 10% 1/10W
VT7	2N743 } matched pair	44522-033	R15	Met ox 33kΩ 7% 3/8W*	24552-122
VT8			2N743	R16	Met ox 4.7kΩ 7% 3/8W*
	Fuse holder for 25FS1	43281-003	R17	Met ox 33kΩ 7% 3/8W*	24552-122
			R18	Met ox 10kΩ 7% 3/8W*	24552-110
<b>Unit 26 —A.L.C. and Envelope Feedback, TM 7186</b>			R19	Met ox 4.7kΩ 7% 3/8W*	24552-100
When ordering, prefix circuit reference with 26			R20	Met ox 10kΩ 7% 3/8W*	24552-110
C1	Elec 500μF +100-20% 25V	26417-175	R21	Met ox 4.7kΩ 7% 3/8W*	24552-100
C2	Plas 220pF 2% 125V	26516-327	R22	Met ox 10kΩ 7% 3/8W*	24552-110
C3	Plas 0.001μF 2% 125V	26516-481	R23	Met ox 4.7kΩ 7% 3/8W*	24552-100
C4	Cer 0.01μF +80-20% 350V	26383-392	R24	Met ox 10kΩ 7% 3/8W*	24552-110
C5	Cer 0.22μF +50-25% 6V	26383-034	R25	Met ox 4.7kΩ 7% 3/8W*	24552-100
C6	Cer 0.22μF +50-25% 6V	26383-034	R29	Met ox 33kΩ 7% 3/8W*	24552-122
C7	Elec 1μF +100-20% 50V	26414-106	R30	Met ox 1kΩ 7% 3/8W*	24552-080
C8	Elec 1μF +100-20% 50V	26414-106	R31	Met ox 1kΩ 7% 3/8W*	24552-080
C9	Cer 0.01μF +80-20% 350V	26383-392	R32	Met ox 33kΩ 7% 3/8W*	24552-122
C10	Elec 50μF +100-20% 6V	26412-245	R33	Carb 50Ω 1% 1/8W	24112-500
C12	Paper 300pF 20% 500V	26174-119	R34	Carb 1kΩ 10% 1/10W	24341-280
C13 †	Cer 1.0pF ±1pF 750V	26324-020	R35	Met ox 2.2kΩ 7% 3/8W*	24552-088
C14 †	Cer 1.0pF ±1pF 750V	26324-020	R36	Met ox 100Ω 7% 3/8W*	24552-050
C16	Cer 0.01μF +80-20% 100V	26383-055	R37	Carb 1.8kΩ 10% 1/10W	24341-286
			R38	Carb 10Ω 10% 1/2W	24342-020

For symbols and abbreviations see introduction to this chapter

When ordering, prefix circuit reference with 26

Circuit reference	Description	M.I. code	
RV1	Carb 1k $\Omega$ 20% $\frac{1}{4}$ W	25611-014	
RV2	Carb 1k $\Omega$ 20% $\frac{1}{4}$ W	25611-014	
VT1	BCY71 } matched trio including R1, R2 and R10	46883-070	
VT4			BCY71
VT5			BC108
VT2	HT101 } matched pair	44522-026	
VT6			HT101
VT3	HT101	28432-735	
VT7	BSX20	28452-197	
VT8	BSX20	28452-197	

**Unit (27) —Coarse Attenuator, TM 8968**

When ordering, prefix circuit reference with 27

R1	Met film 53.3 $\Omega$ 0.5% $\frac{1}{4}$ W	24634-356
R2	Met film 790 $\Omega$ 0.5% $\frac{1}{4}$ W	24634-806
R3	Met film 53.3 $\Omega$ 0.5% $\frac{1}{4}$ W	24634-356
R4	Met film 53.3 $\Omega$ 0.5% $\frac{1}{4}$ W	24634-356
R5	Met film 790 $\Omega$ 0.5% $\frac{1}{4}$ W	24634-806
R6	Met film 53.3 $\Omega$ 0.5% $\frac{1}{4}$ W	24634-356
R7	Met film 61 $\Omega$ 0.5% $\frac{1}{4}$ W	24634-357
R8	Met film 247 $\Omega$ 0.5% $\frac{1}{4}$ W	24634-609
R9	Met film 61 $\Omega$ 0.5% $\frac{1}{4}$ W	24634-357
R10	Met film 61 $\Omega$ 0.5% $\frac{1}{4}$ W	24634-357
R11	Met film 247 $\Omega$ 0.5% $\frac{1}{4}$ W	24634-609
R12	Met film 61 $\Omega$ 0.5% $\frac{1}{4}$ W	24634-357
R13	Met film 61 $\Omega$ 0.5% $\frac{1}{4}$ W	24634-357
R14	Met film 247 $\Omega$ 0.5% $\frac{1}{4}$ W	24634-609
R15	Met film 61 $\Omega$ 0.5% $\frac{1}{4}$ W	24634-357

**Unit (28) —Fine Attenuator, TM 8967**

When ordering, prefix circuit reference with 28

R1	Met film 150 $\Omega$ 1% $\frac{1}{4}$ W	24636-615
R2	Met film 37.3 $\Omega$ 1% $\frac{1}{4}$ W	24636-235

When ordering, prefix circuit reference with 28

Circuit reference	Description	M.I. code
R3	Met film 150 $\Omega$ 1% $\frac{1}{4}$ W	24636-615
R4	Met film 292 $\Omega$ 1% $\frac{1}{4}$ W	24636-714
R5	Met film 17.6 $\Omega$ 1% $\frac{1}{4}$ W	24636-116
R6	Met film 292 $\Omega$ 1% $\frac{1}{4}$ W	24636-714
R7	Met film 870 $\Omega$ 1% $\frac{1}{4}$ W	24636-906
R8	Met film 5.77 $\Omega$ 0.5% $\frac{1}{4}$ W	24634-052
R9	Met film 870 $\Omega$ 1% $\frac{1}{4}$ W	24636-906
R10	Met film 436 $\Omega$ 1% $\frac{1}{4}$ W	24636-713
R11	Met film 11.6 $\Omega$ 1% $\frac{1}{4}$ W	24636-115
R12	Met film 436 $\Omega$ 1% $\frac{1}{4}$ W	24636-713
R13	Met film 96.3 $\Omega$ 0.5% $\frac{1}{4}$ W	24634-481
R14	Met film 71.2 $\Omega$ 0.5% $\frac{1}{4}$ W	24634-355
R15	Met film 96.3 $\Omega$ 0.5% $\frac{1}{4}$ W	24634-481

**Unit (29) —Capacitor Board, TM 7595/1**

When ordering, prefix circuit reference with 29

C1	Plas 0.372 $\mu$ F $\frac{1}{2}$ % 125V	26516-879
C2	Plas 0.118 $\mu$ F $\frac{1}{2}$ % 125V	26516-856
C3	Plas 0.0372 $\mu$ F $\frac{1}{2}$ % 125V	26516-815
C4	Plas 0.0118 $\mu$ F $\frac{1}{2}$ % 125V	26516-721
C5	Plas 0.00372 $\mu$ F 1% 125V	26516-623
C6	Plas 0.0011 $\mu$ F 2% 125V	26516-494
C7	Plas 0.372 $\mu$ F $\frac{1}{2}$ % 125V	26516-879
C8	Plas 0.118 $\mu$ F $\frac{1}{2}$ % 125V	26516-856
C9	Plas 0.0372 $\mu$ F $\frac{1}{2}$ % 125V	26516-815
C10	Plas 0.0118 $\mu$ F $\frac{1}{2}$ % 125V	26516-721
C11	Plas 0.00372 $\mu$ F 1% 125V	26516-623
C12	Plas 0.0011 $\mu$ F 2% 125V	26516-494
C13	Elec 1000 $\mu$ F +100-20% 12V	26417-403
C14 †	Plas 33pF $\pm$ 2pF 125V	26516-127
C15 †	Plas 33pF $\pm$ 2pF 125V	26516-127

**Unit (30) —Coarse Tracking Potentiometer, TM 9063**

When ordering, prefix circuit reference with 30

R1	Met ox 220 $\Omega$ 7% $\frac{3}{8}$ W*	24552-058
R2	Met ox 200 $\Omega$ 7% $\frac{3}{8}$ W*	24552-057
R3	Met ox 180 $\Omega$ 7% $\frac{3}{8}$ W*	24552-056

For symbols and abbreviations see introduction to this chapter

Replaceable parts

When ordering, prefix circuit reference with 30

Circuit reference	Description	M.I. code
R4	Met ox 160Ω 7% $\frac{3}{8}W^*$	24552-055
R5	Met ox 150Ω 7% $\frac{3}{8}W^*$	24552-054
R6	Met ox 130Ω 7% $\frac{3}{8}W^*$	24552-053
R7	Met ox 120Ω 7% $\frac{3}{8}W^*$	24552-052
R8	Met ox 110Ω 7% $\frac{3}{8}W^*$	24552-051
R9	Met ox 100Ω 7% $\frac{3}{8}W^*$	24552-050
R10	Met ox 91Ω 7% $\frac{3}{8}W^*$	24552-047
R11	Met ox 82Ω 7% $\frac{3}{8}W^*$	24552-046
R12	Met ox 75Ω 7% $\frac{3}{8}W^*$	24552-044
R13	Met ox 68Ω 7% $\frac{3}{8}W^*$	24552-043
R14	Met ox 62Ω 7% $\frac{3}{8}W^*$	24552-041
R15	Met ox 56Ω 7% $\frac{3}{8}W^*$	24552-040
R16	Met ox 51Ω 7% $\frac{3}{8}W^*$	24552-038
R17	Met ox 47Ω 7% $\frac{3}{8}W^*$	24552-037
R18	Met ox 43Ω 7% $\frac{3}{8}W^*$	24552-036
R19	Met ox 39Ω 7% $\frac{3}{8}W^*$	24552-035
R20	Met ox 36Ω 7% $\frac{3}{8}W^*$	24552-034

When ordering, prefix circuit reference with 31

Circuit reference	Description	M.I. code
R21	Met ox 33Ω 7% $\frac{3}{8}W^*$	24552-033
R22	Met ox 30Ω 7% $\frac{3}{8}W^*$	24552-032
R23	Met ox 27Ω 7% $\frac{3}{8}W^*$	24552-031
R24	Met ox 24Ω 7% $\frac{3}{8}W^*$	24552-029
R25	Met ox 240Ω 7% $\frac{3}{8}W^*$	24552-060

Unit 31 — TM 9738

When ordering, prefix circuit reference with 31

R1 †	Met ox 82kΩ 7% $\frac{3}{8}W^*$	24552-133
R2 †	Met ox 82kΩ 7% $\frac{3}{8}W^*$	24552-133
R3 †	Carb 470kΩ 10% $\frac{1}{2}W$	24342-152
R4 †	Carb 470kΩ 10% $\frac{1}{2}W$	24342-152
R5 †	Met ox 220kΩ 7% $\frac{3}{8}W^*$	24552-143
R6 †	Met ox 470kΩ 10% $\frac{1}{2}W$	24342-152

For symbols and abbreviations see introduction to this chapter



## 1. COMPONENT VALUES

Resistors: No suffix = ohms, k = kilohms, M = megohms.

Capacitors: No suffix = microfarads, p = picofarads.

† value selected during test, nominal value shown.

## 2. VOLTAGES

Shown in italics adjacent to the point to which the measurement refers. See section 4.5 for conditions.

## 3. SYMBOLS

 arrow indicates clockwise rotation of knob.

 etc., external front or rear panel marking.

 tag on printed board.

 other tag.

 preset control.

 unit identification number.

 point marked with this symbol is connected to and receives power from

 point marked with this symbol

These symbols are used to identify branches of the power supply circuitry but have no particular physical reality on the printed boards.

## 4. CIRCUIT REFERENCES

These are, in general, given in abbreviated form.

See also introduction to section 6.1.

## 5. SWITCHES

Rotary switches are drawn schematically.

Letters indicate control knob settings.

1F = 1st section (front panel), front

1B = 1st section, back

2F = 2nd section, front

etc.

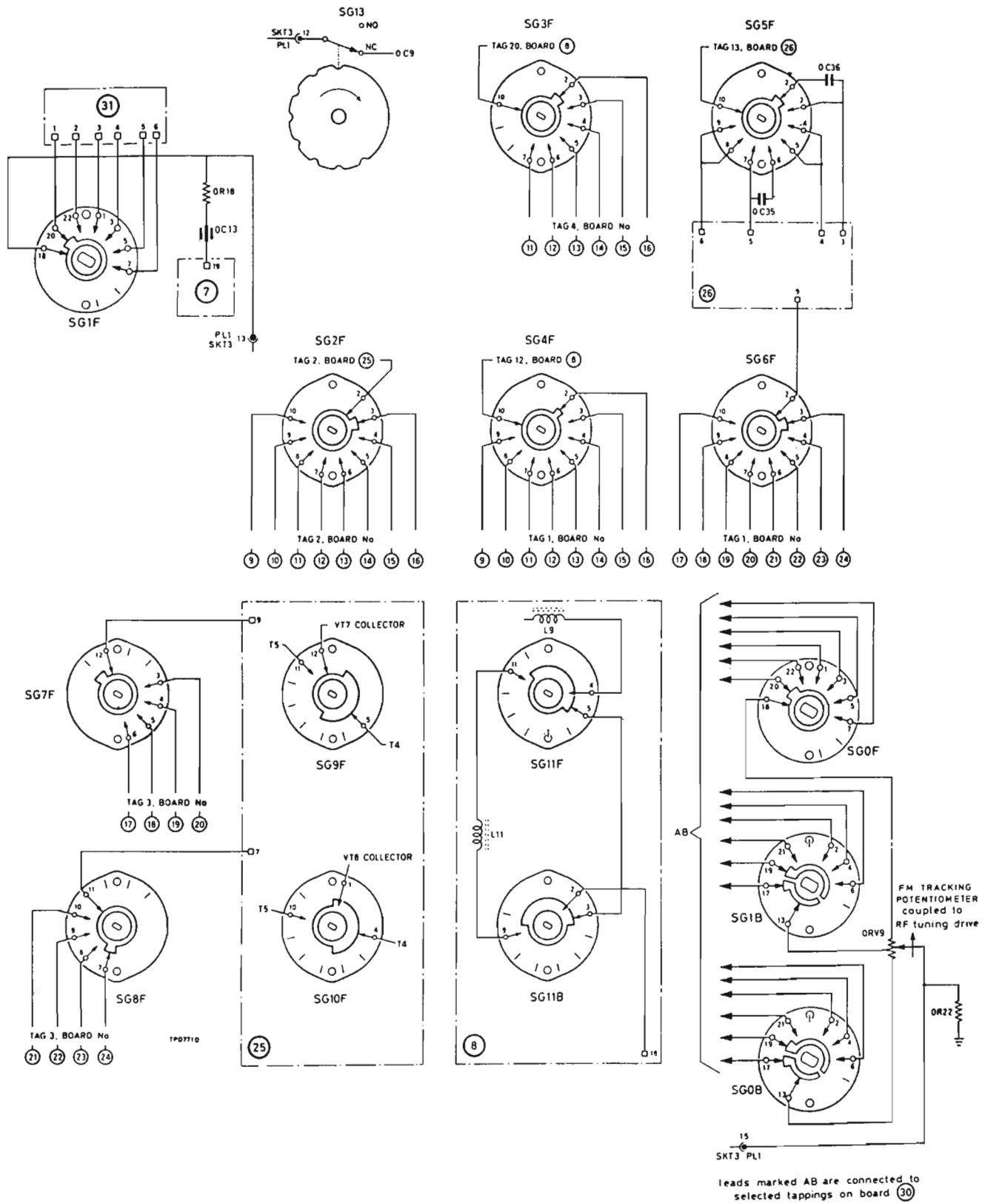

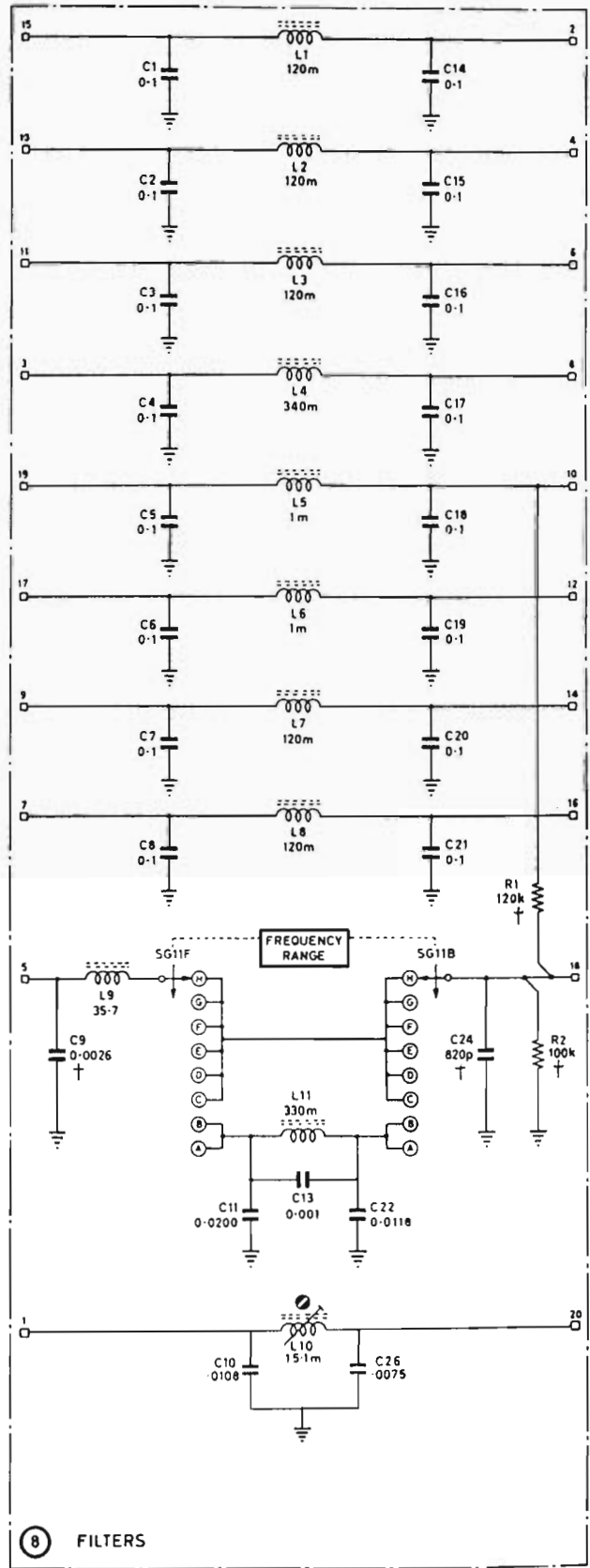
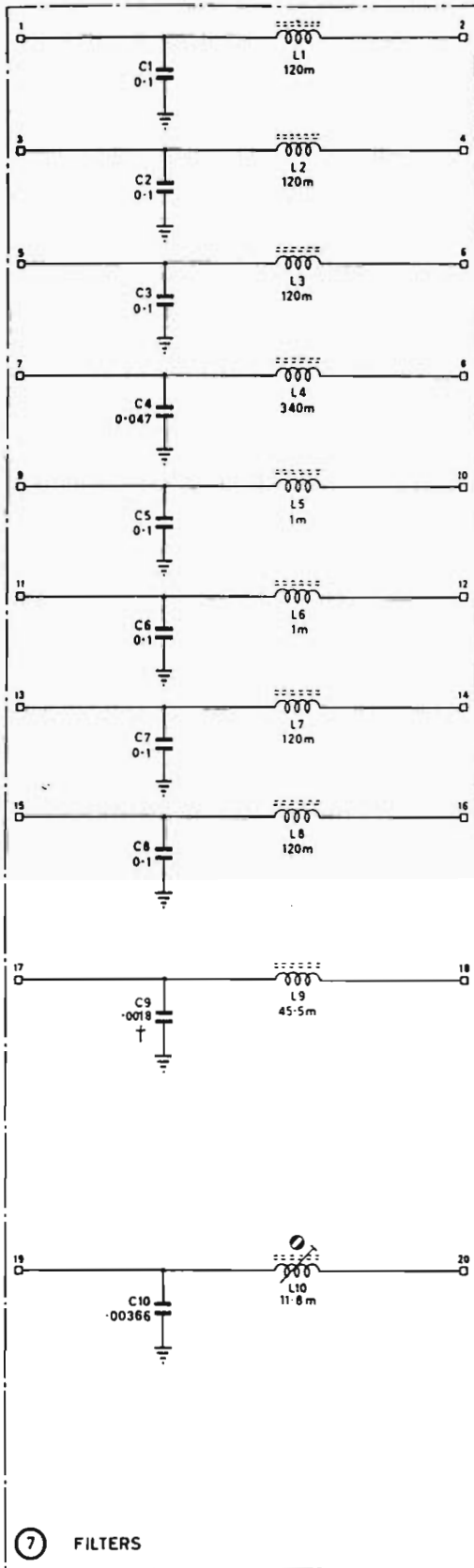

TPD769 D

Fig. 7.10 R.F. unit filters



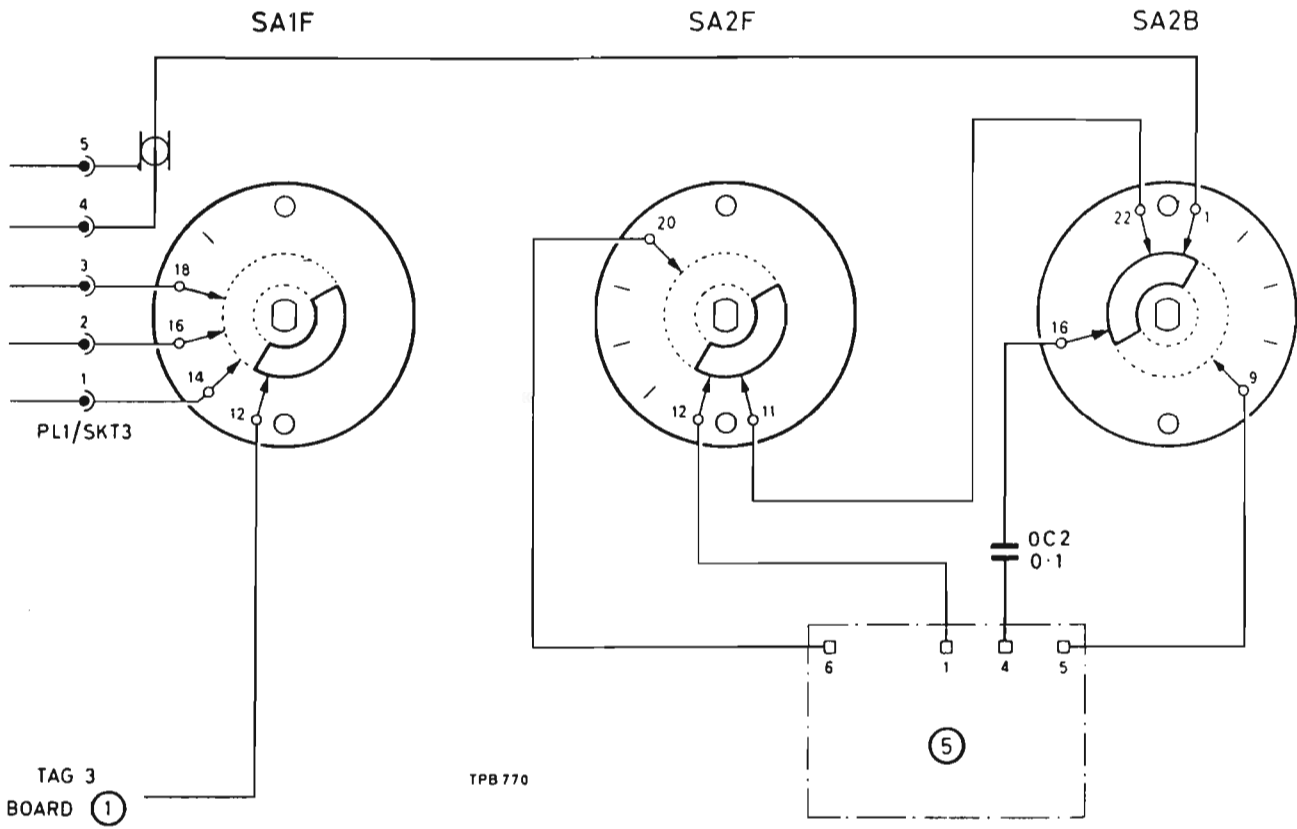

SA—plan of sections viewed from knob end  
with switch in fully counter-clockwise position

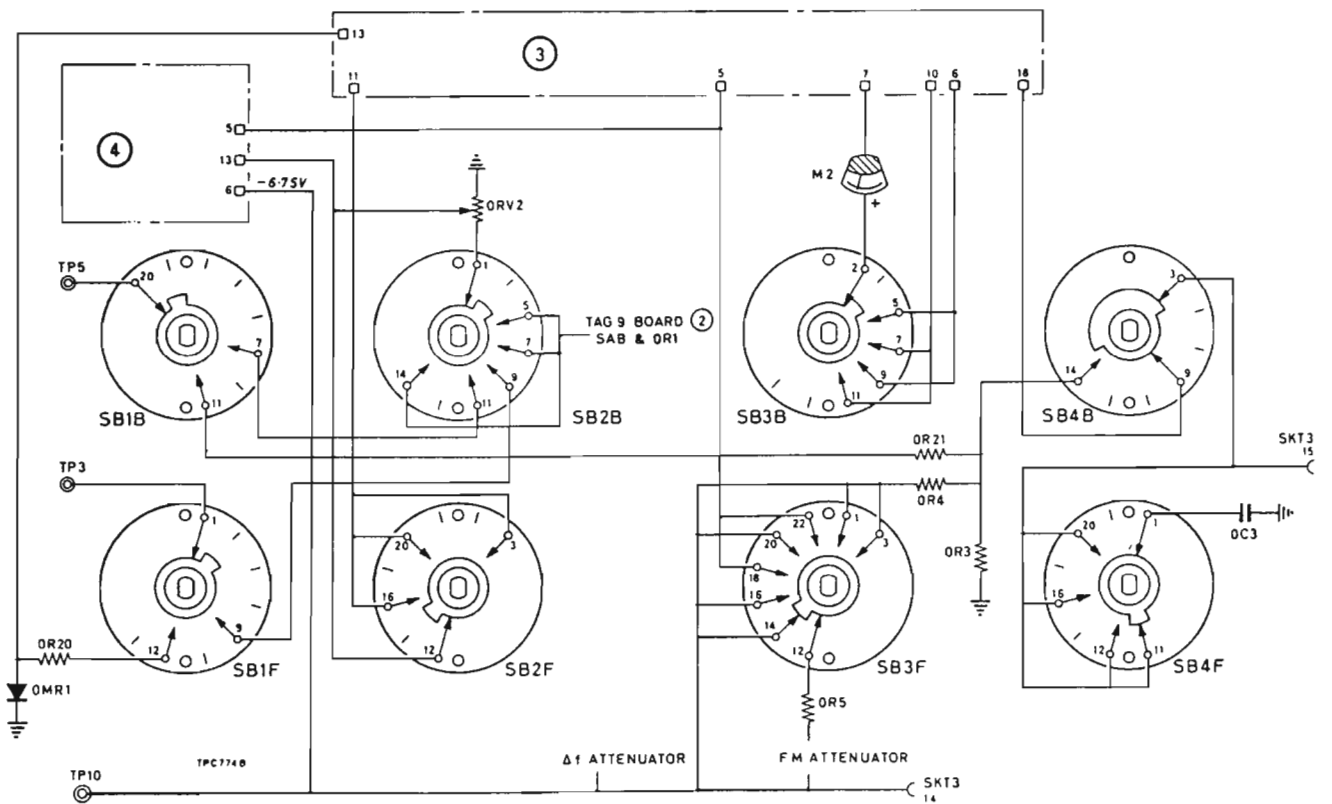

SB—plan of sections viewed from knob end  
with switch in fully counter-clockwise position

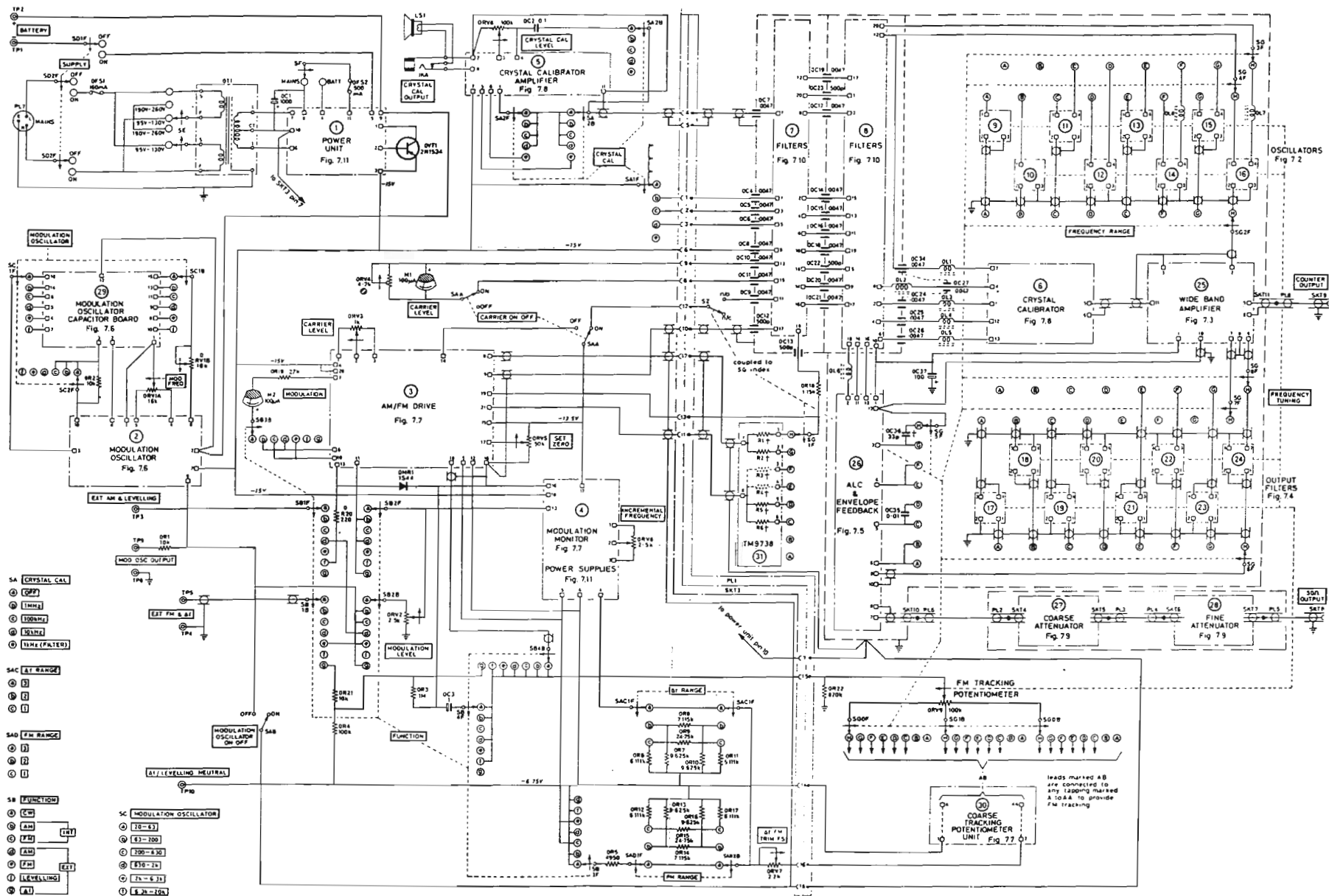
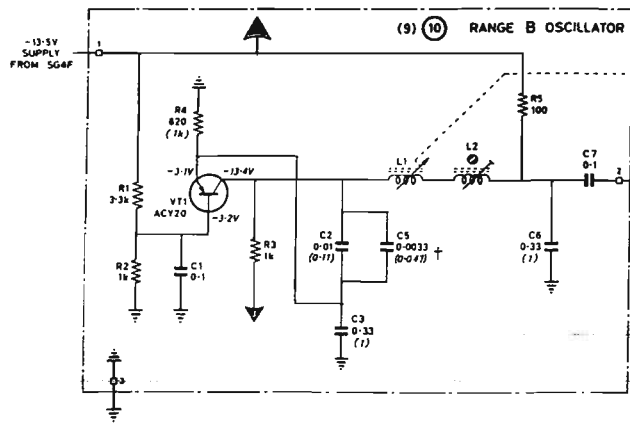
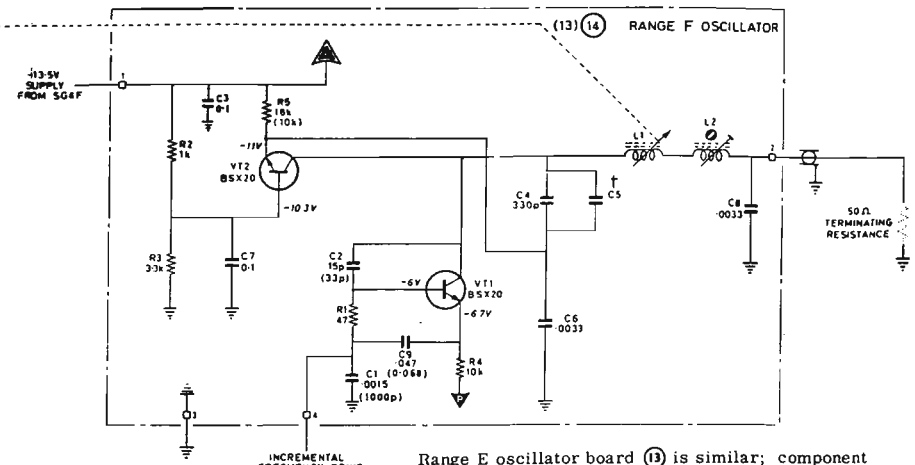

Fig. 7.1 Interconnecting diagram



Range A oscillator board (9) is similar; component values that are different are shown in brackets.

COUPLED TO RF TUNING DRIVE



Range E oscillator board (13) is similar; component values that are different are shown in brackets.

INCREMENTAL FREQUENCY DRIVE FROM SG3F

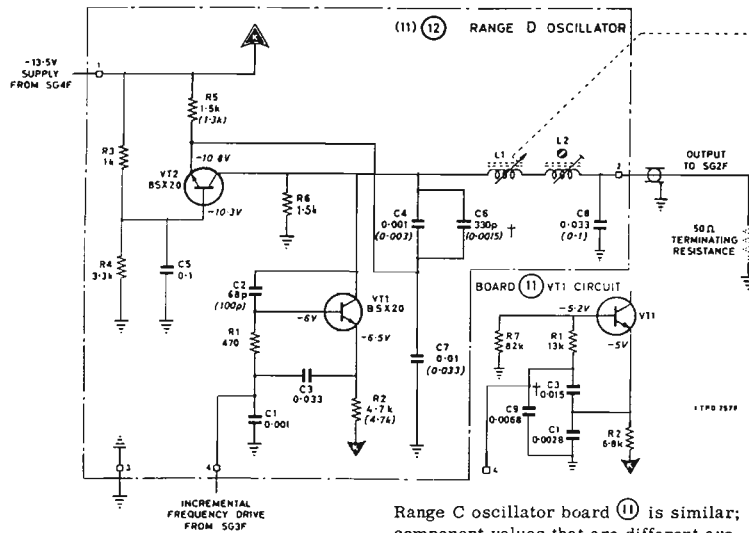

Range C oscillator board (11) is similar; component values that are different are shown in brackets.

17PD 7577

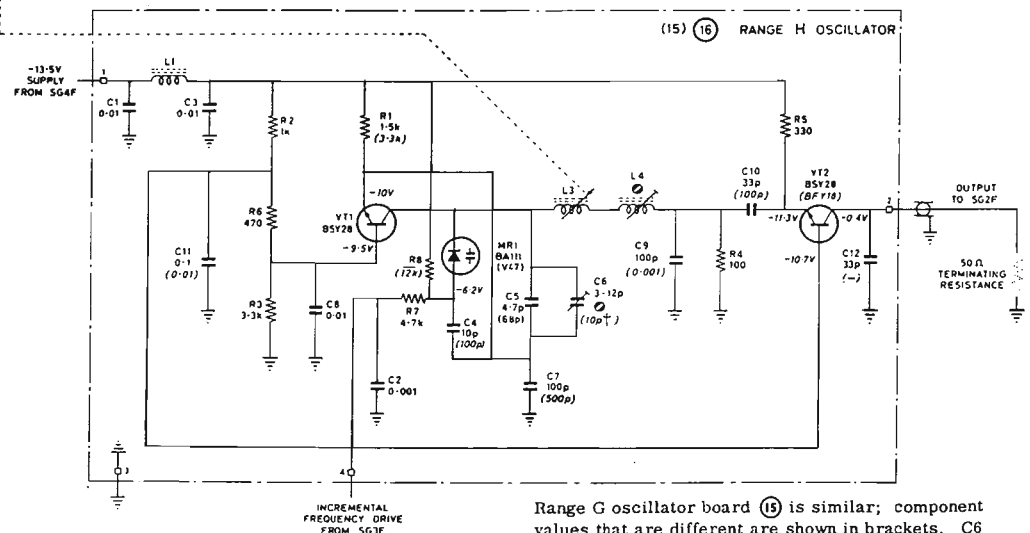

Range G oscillator board (15) is similar; component values that are different are shown in brackets. C6 is a fixed capacitor and C12 is not fitted.

INCREMENTAL FREQUENCY DRIVE FROM SG3F

Fig. 7.2 Oscillators

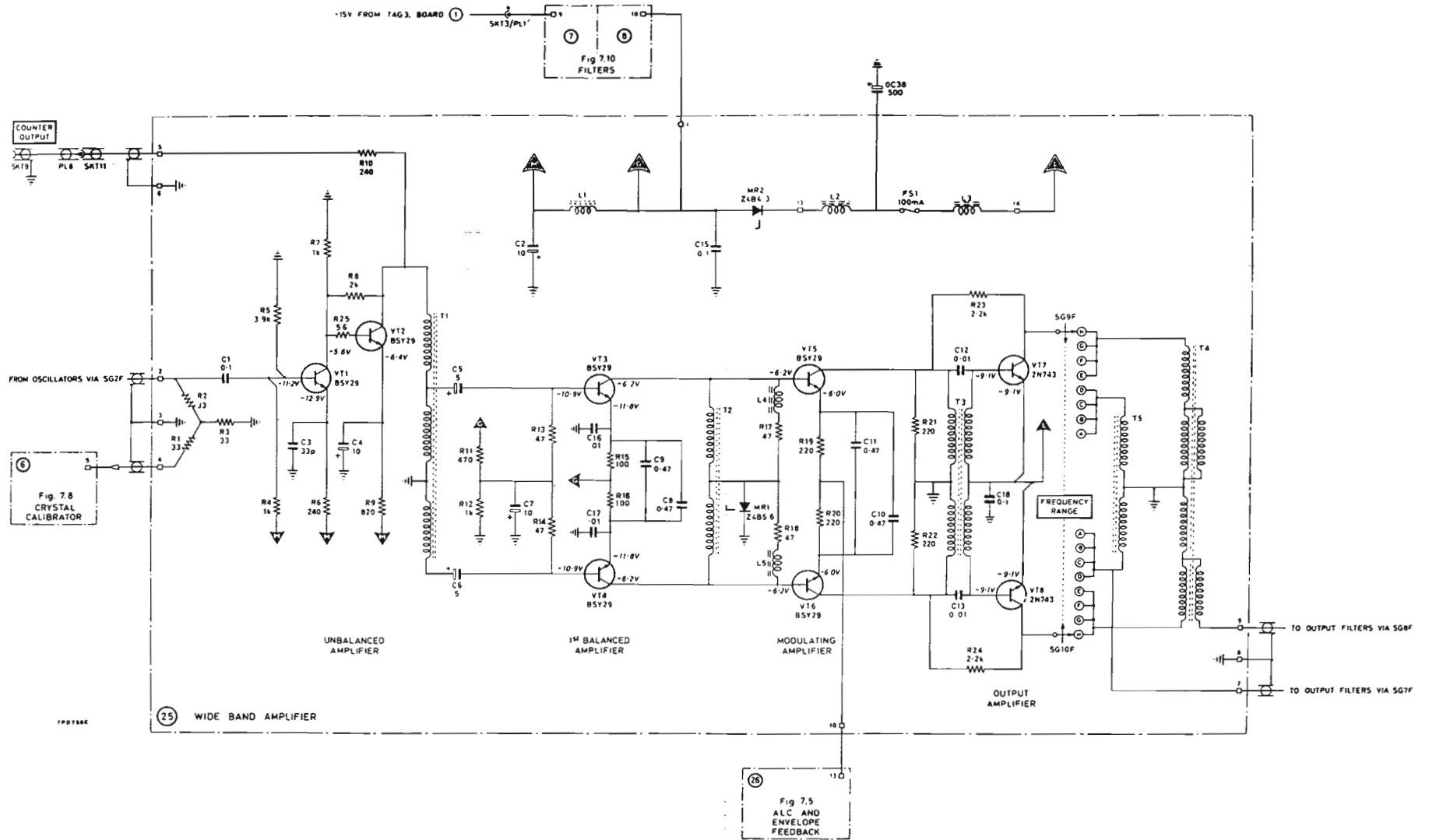

Fig. 7.3 Wide band amplifier

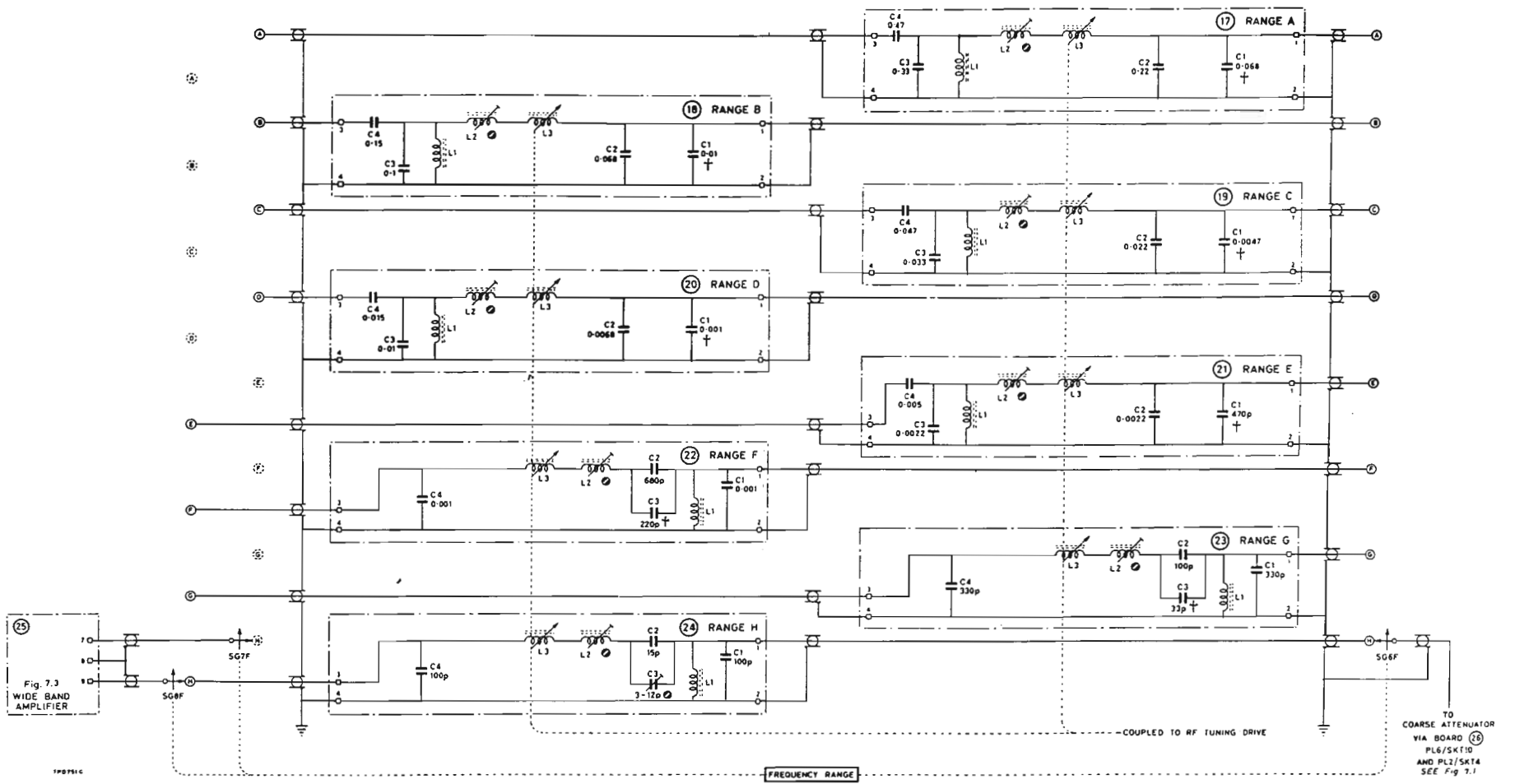

Fig. 7.4 Carrier filters

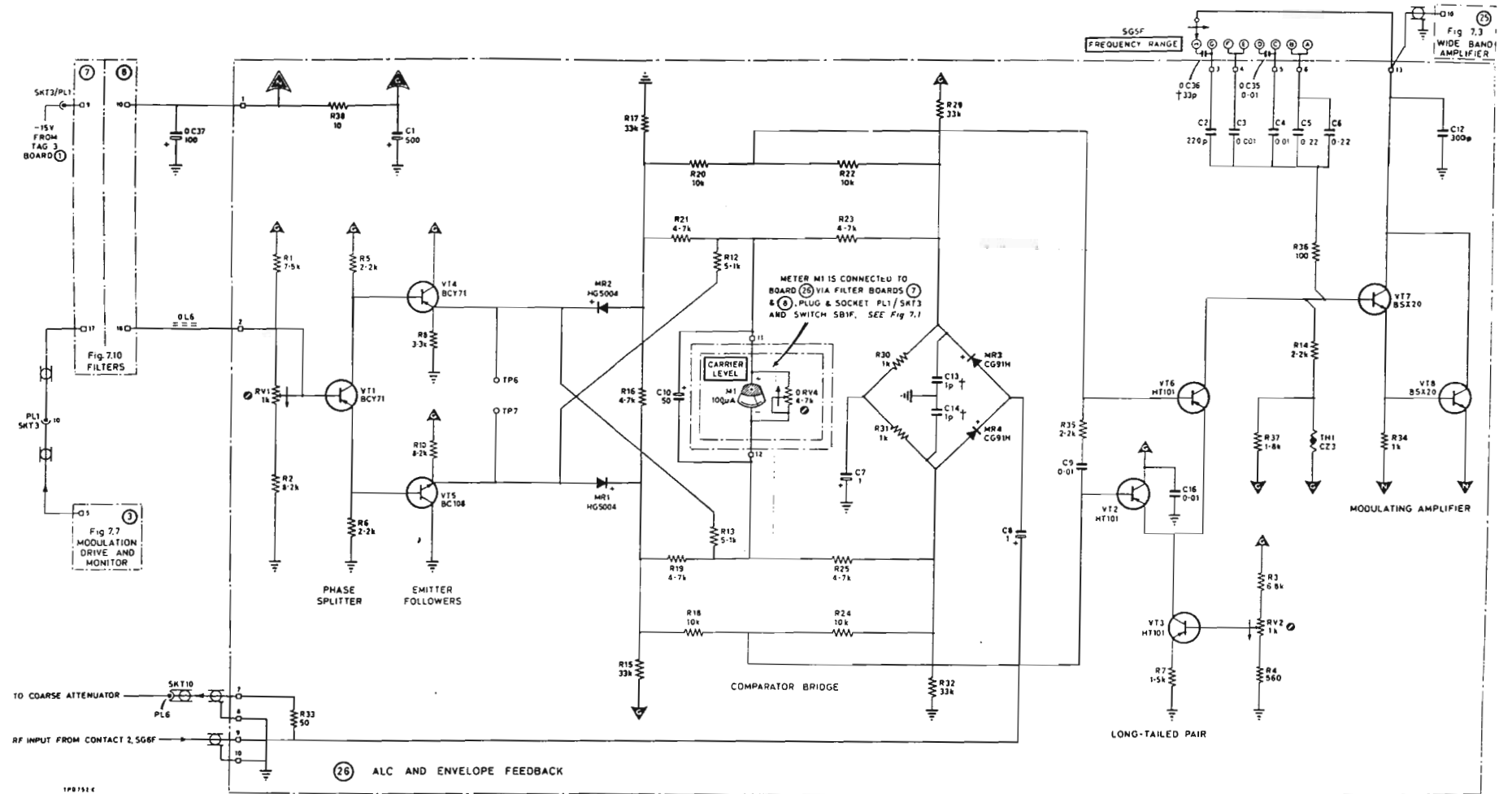

Fig. 7.5 A.L.C. and envelope feedback

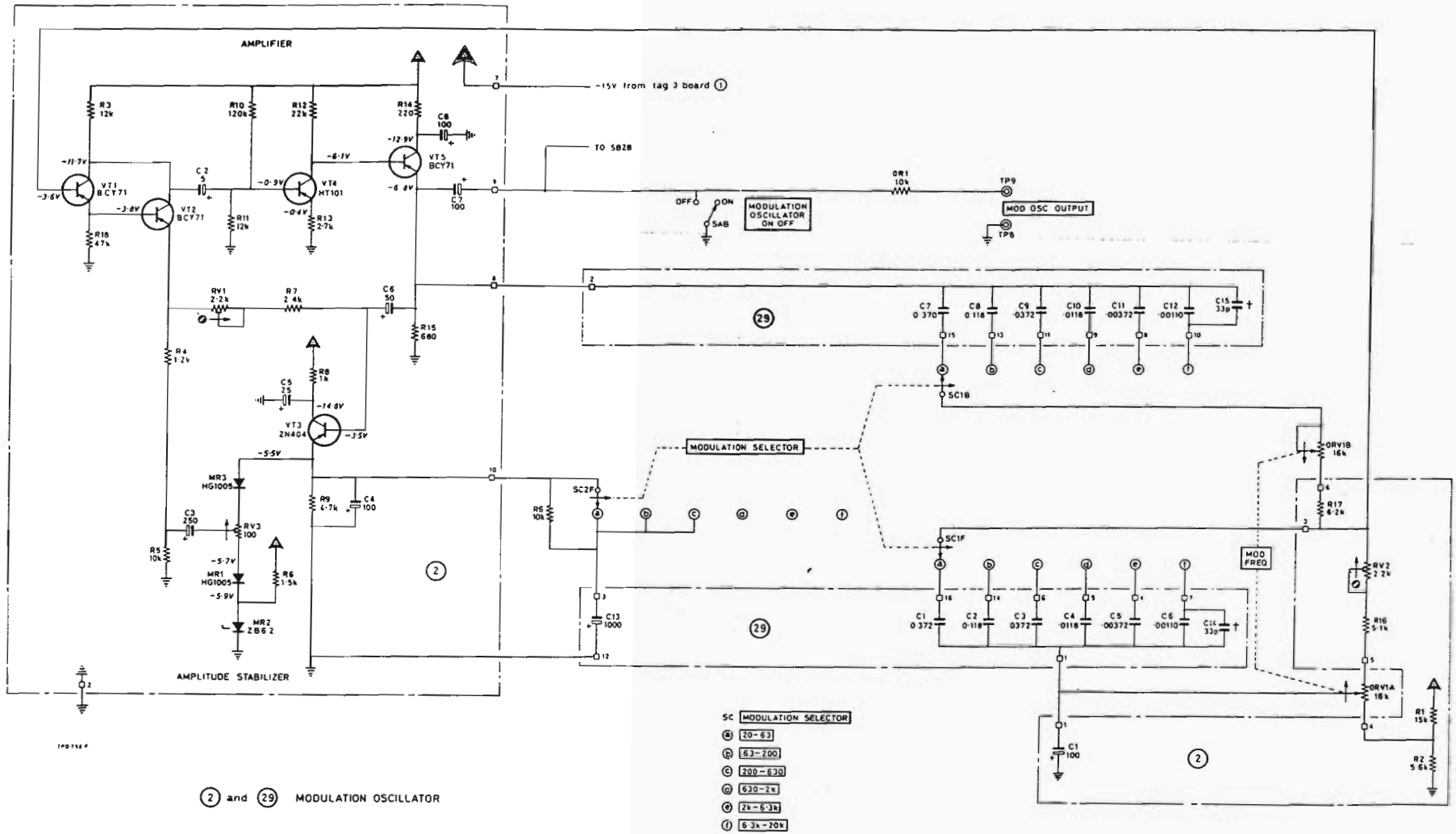

Fig. 7.6 Modulation oscillator



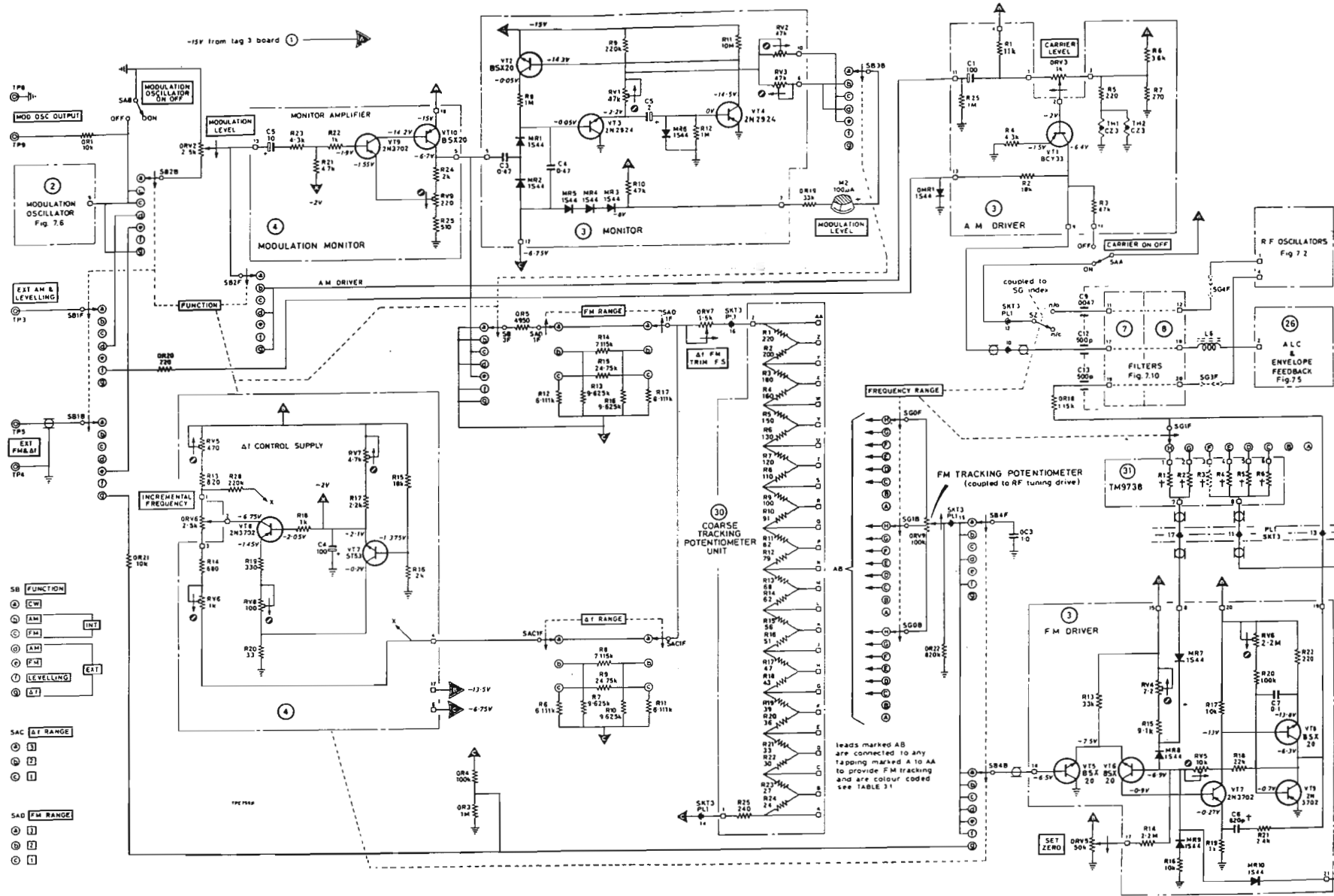

Fig. 7.7 A.M./F.M. drive and monitor

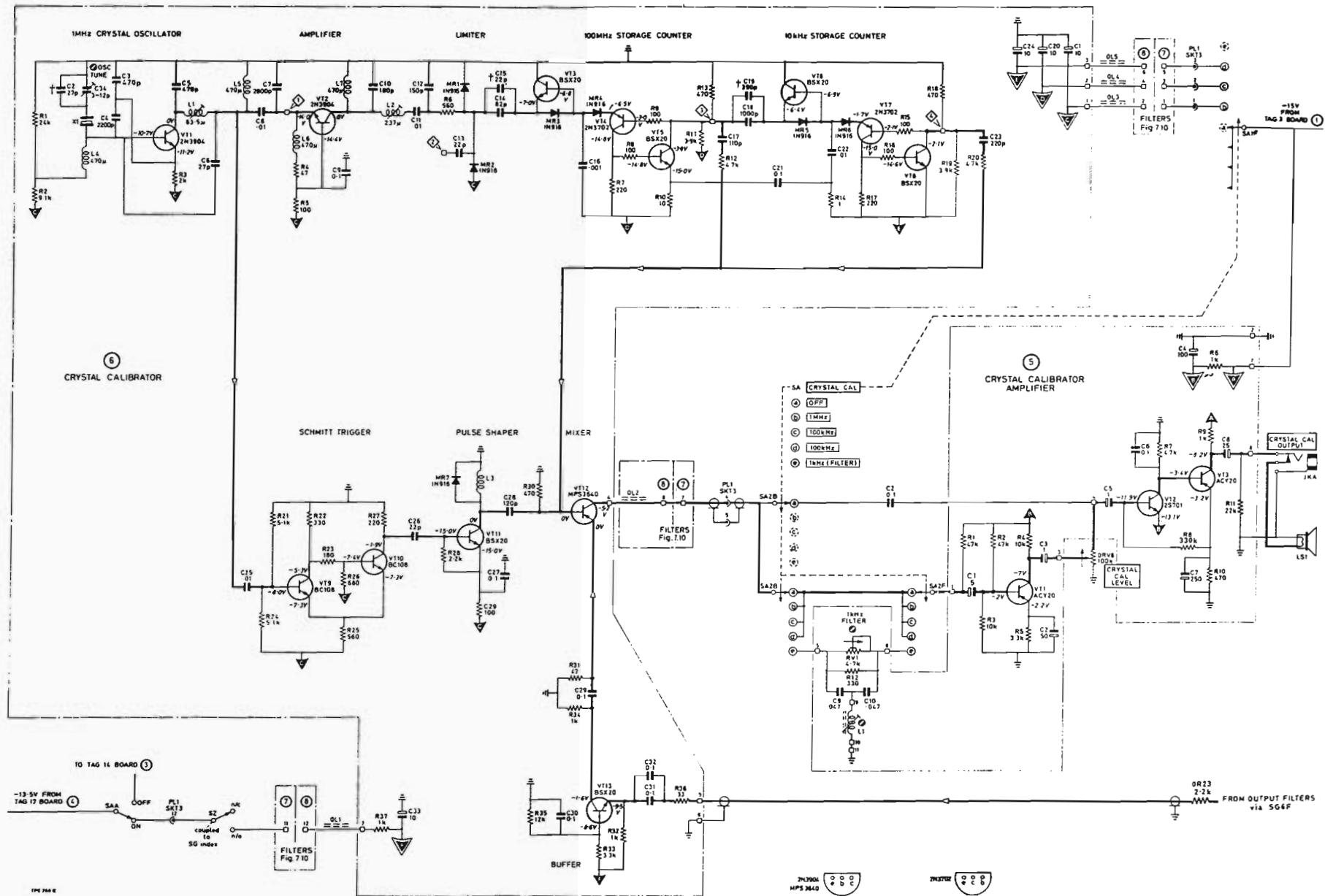
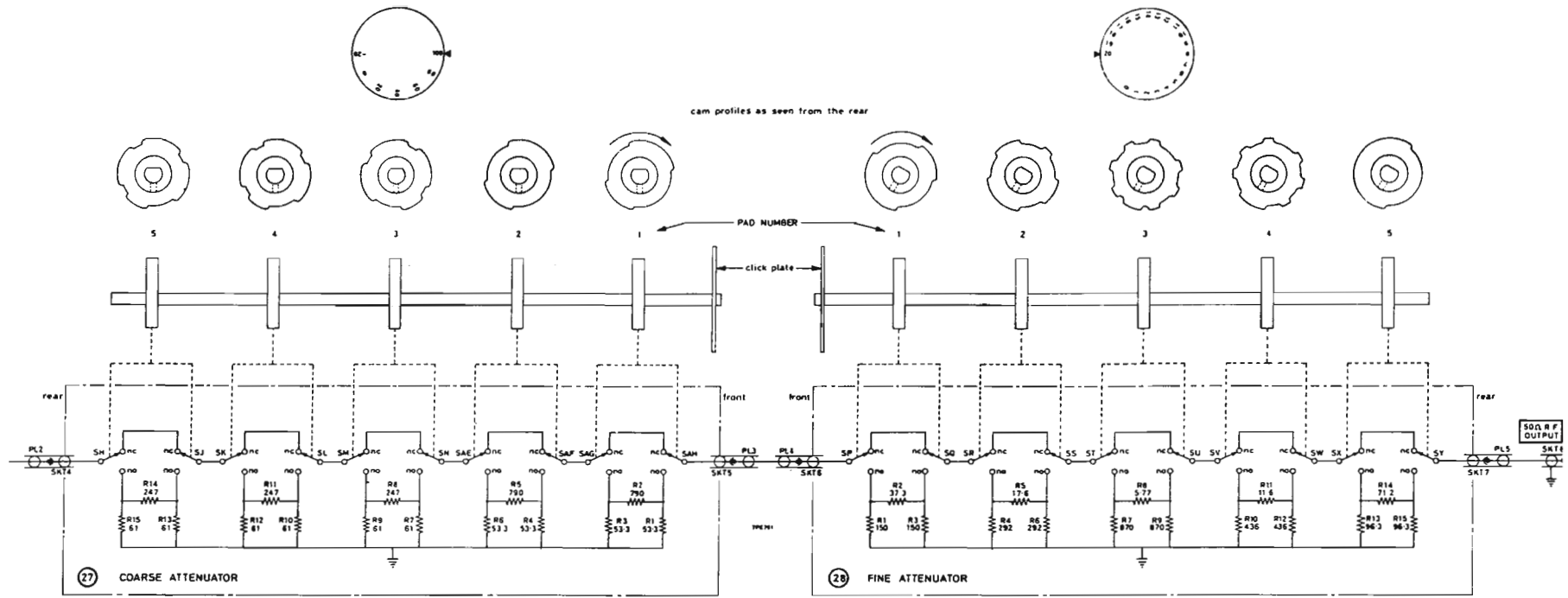
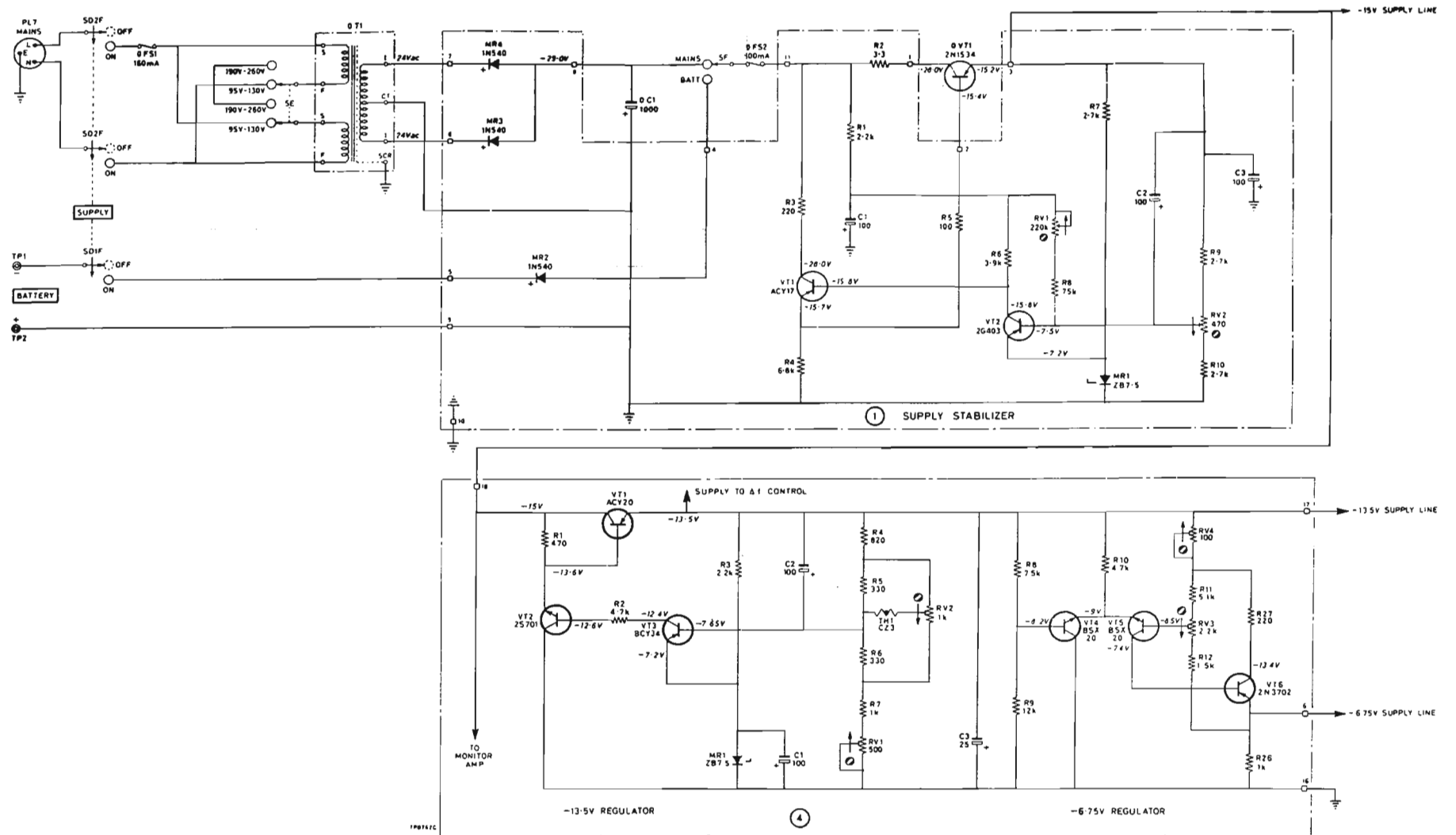

Fig. 7.8 Crystal calibrator



		dB ABOVE 1μV ADD																									
		ATTENUATION dB																									
		PAD SECTIONS IN CIRCUIT																									
100	80	60	40	20	0	-20	0	1	2	3	4	5	6	7	8	9	10	11	12	13	14	15	16	17	18	19	20
0	20	40	60	80	100	120	20	19	18	17	16	15	14	13	12	11	10	9	8	7	6	5	4	3	2	1	0
		dB		dB																							
		1		6																							
		2		3																							
		3		1																							
		4		2																							
		5		10																							

Fig. 7.9 Attenuators



NOTE: the earth wire from the mains input plug should be earthed independently of all other earth wires.

Fig. 7.11 Power supplies